

STRATA PLAN OF PART OF LOT 1 SECTION 7 TOWNSHIP 2 NEW WESTMINSTER DISTRICT PLAN EPP73003

PHASE ONE SHEET 1 OF 8 SHEETS
STRATA PLAN EPS5866

BCGS 92G.016

SCALE 1:750



ALL DIMENSIONS ARE IN METRES

THE INTENDED PLOT SIZE OF THIS PLAN IS 280 mm IN WIDTH BY 432 mm IN HEIGHT (B SIZE) WHEN PLOTTED AT A SCALE OF 1:750

INTEGRATED SURVEY AREA NO. 1, SURREY, BC, NAD83 (CSRS) 4.0.0.BC.1.GVRD.

GRID BEARINGS ARE DERIVED FROM OBSERVATIONS BETWEEN GEODETIC CONTROL MONUMENTS 5592 AND 5231 AND ARE REFERRED TO THE CENTRAL MERIDIAN OF UTM ZONE 10

THE UTM COORDINATES AND ESTIMATED HORIZONTAL POSITIONAL ACCURACY ACHIEVED ARE DERIVED FROM THE MASCOT PUBLISHED COORDINATES AND STANDARD DEVIATIONS FOR GEODETIC CONTROL MONUMENTS 5592 AND 5231

THIS PLAN SHOWS HORIZONTAL GROUND-LEVEL DISTANCES UNLESS OTHERWISE SPECIFIED. TO COMPUTE GRID DISTANCES, MULTIPLY GROUND-LEVEL DISTANCES BY THE AVERAGE COMBINED FACTOR OF 0.9995958 WHICH HAS BEEN DERIVED FROM GEODETIC CONTROL MONUMENTS 5592 AND 5231



CIVIC ADDRESS:

12073 62nd AVENUE
SURREY, BC

LEGEND

- ⊕ INDICATES CONTROL MONUMENT FOUND
- INDICATES STANDARD IRON POST FOUND
- ⊙ INDICATES COMMON PROPERTY
- ELEC INDICATES ELECTRICAL CLOSET
- D INDICATES DECK
- PT INDICATES PART

5592
UTM Zone 10 coordinates
Datum: NAD83(CSRS) 4.0.0.BC.1.GVRD.
UTM easting: 507998.428
UTM northing: 5439478.491
Point combined factor: 0.9995957
Estimated Horizontal Positional Accuracy: 0.02m

5231
UTM Zone 10 coordinates
Datum: NAD83(CSRS) 4.0.0.BC.1.GVRD.
UTM easting: 507998.997
UTM northing: 5439222.540
Point combined factor: 0.9995960
Estimated Horizontal Positional Accuracy: 0.02m

STRATA LOT MEASUREMENTS ARE 90° OR 45° UNLESS NOTED OTHERWISE.
STRATA LOT DIMENSIONS ARE MEASURED TO:
- OUTSIDE OF EXTERIOR STRUCTURAL WALLS
- CENTERLINE OF PARTY WALLS

DECK AREAS ARE LIMITED COMMON PROPERTIES FOR THE USE OF THE STRATA LOT INDICATED (eg: D-1)

DECK AREAS ARE DEFINED AS TO HEIGHT BY THE CENTRE OF THE FLOOR ABOVE OR ITS EXTENSIONS, OR WHERE THERE IS NO FLOOR ABOVE BY THE AVERAGE HEIGHT OF STRATA LOTS WITHIN THE SAME BUILDING, UNLESS OTHERWISE NOTED.

**H.Y. AND ASSOCIATES
LAND SURVEYING LTD.**
200, 9128 - 152 STREET
SURREY, B.C.
V3R 4E7
(ph) 583-1616
File: 154271_PH1_PG1.DWG

THIS PLAN IS PHASE 1 OF A 3 PHASE STRATA PLAN UNDER SECTION 224 OF THE STRATA PROPERTY ACT LYING WITHIN THE JURISDICTION OF THE APPROVING OFFICER FOR CITY OF SURREY

THIS PLAN LIES WITHIN THE METRO VANCOUVER REGIONAL DISTRICT - CITY OF SURREY

THE BUILDINGS INCLUDED IN THIS STRATA PLAN HAVE NOT BEEN PREVIOUSLY OCCUPIED.

THE BUILDINGS SHOWN ON THIS STRATA PLAN ARE WITHIN THE EXTERNAL BOUNDARIES OF THE LAND THAT IS THE SUBJECT OF THE STRATA PLAN.

THE FIELD SURVEY REPRESENTED BY THIS PLAN WAS COMPLETED ON THE 12th DAY OF APRIL, 2019
GU GORDON YU, BCLS #808

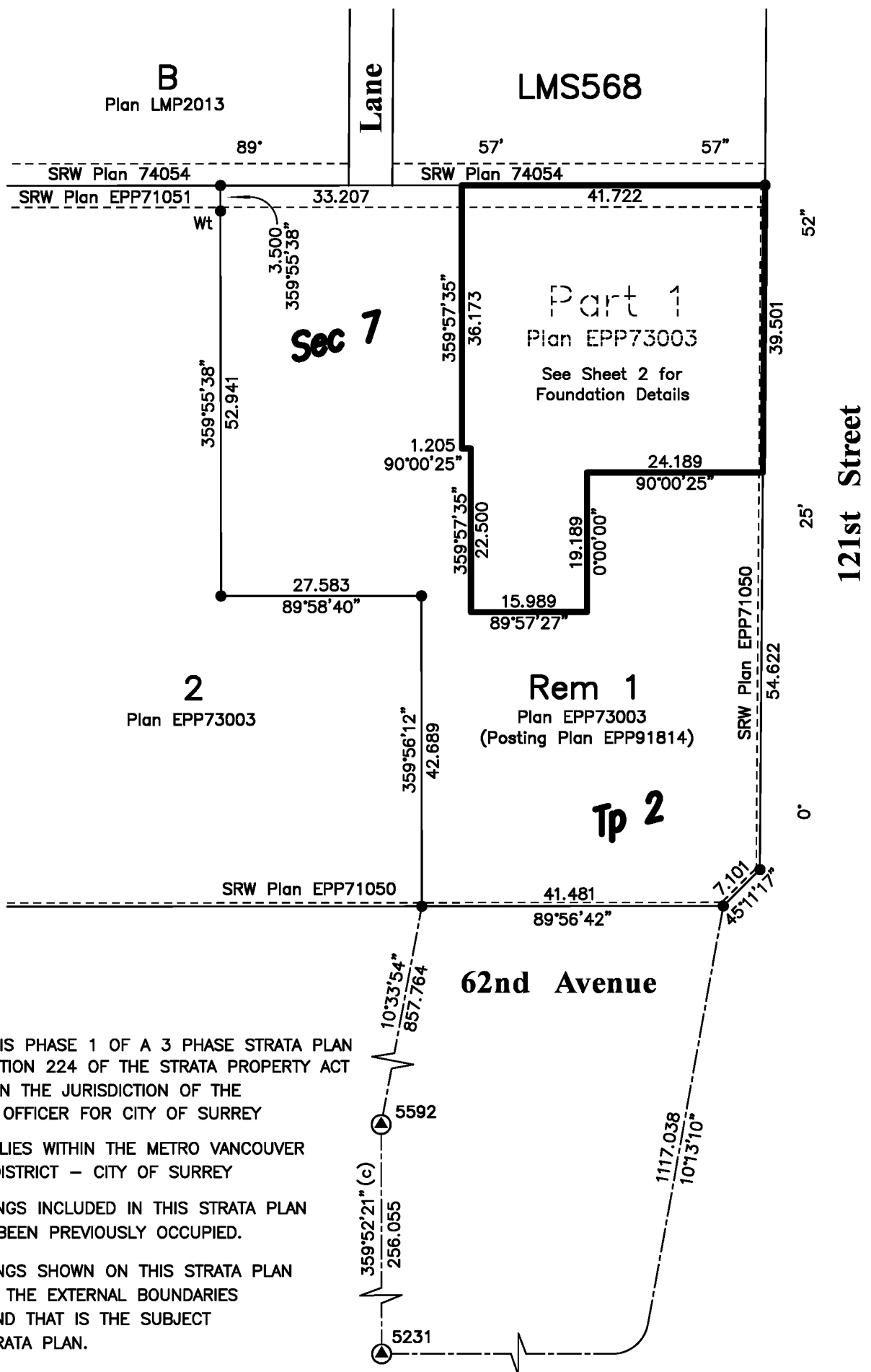

FOUNDATION DETAILS

PHASE 1 STRATA PLAN EPS5866

SHEET 2 OF 8 SHEETS

SCALE 1:250



All distances are in metres.

THE INTENDED PLOT SIZE OF THIS PLAN IS 280 mm IN WIDTH BY 432 mm IN HEIGHT (B SIZE) WHEN PLOTTED AT A SCALE OF 1:250

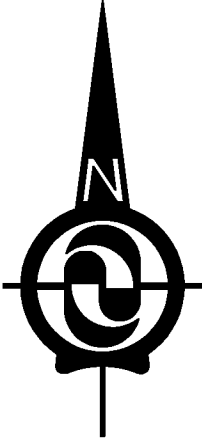

LMS568

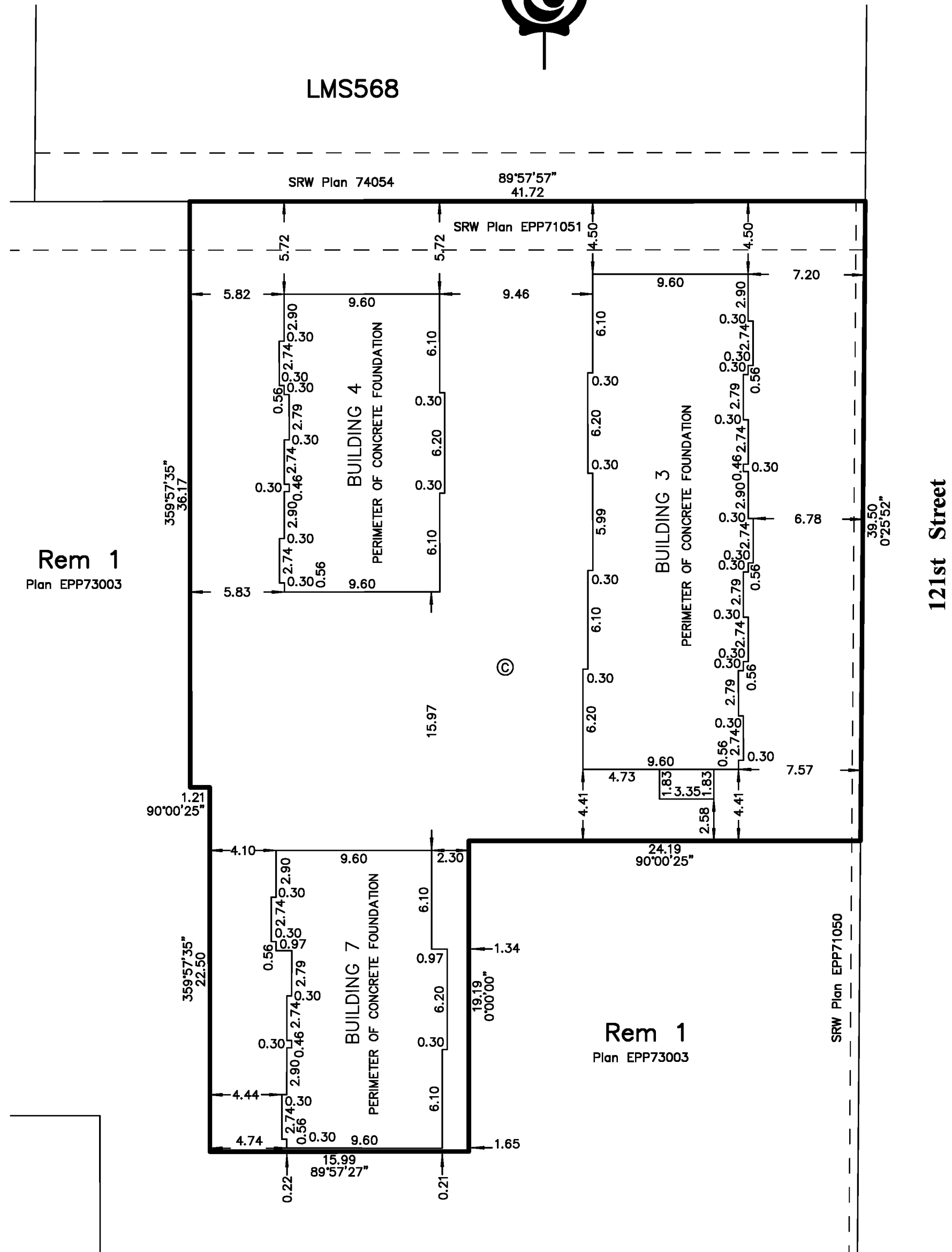

Rem 1
Plan EPP73003

Rem 1
Plan EPP73003

121st Street

**H.Y. AND ASSOCIATES
LAND SURVEYING LTD.**
200, 9128 - 152nd STREET
SURREY, B.C.
V3R 4E7
(ph) 583-1616
File: 154271_PH1_PG2.DWG

GU GORDON YU, BCLS #808
DATE: APRIL 12, 2019

BUILDING 3

SCALE 1:200



All distances are in metres.

THE INTENDED PLOT SIZE OF THIS PLAN IS 280 mm IN WIDTH BY 432 mm IN HEIGHT (B SIZE) WHEN PLOTTED AT A SCALE OF 1:200

----- PERIMETER OF FLOOR BELOW

PHASE 1 STRATA PLAN EPS5866

SHEET 3 OF 8 SHEETS

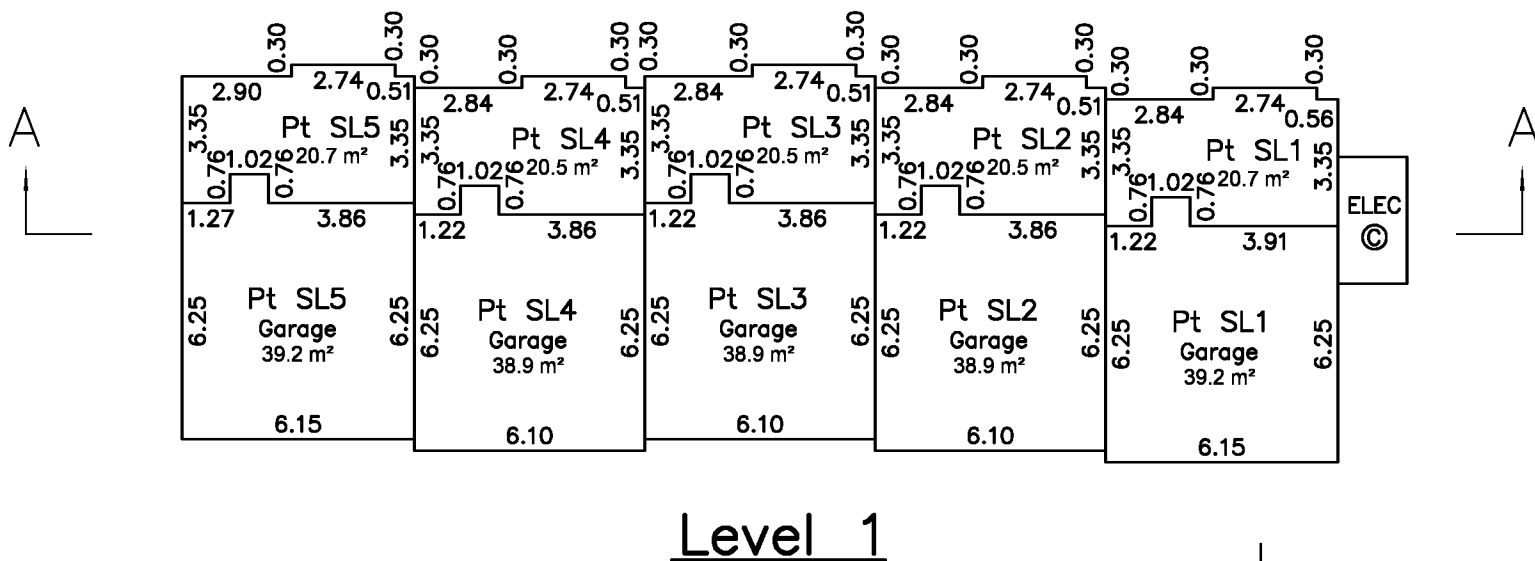
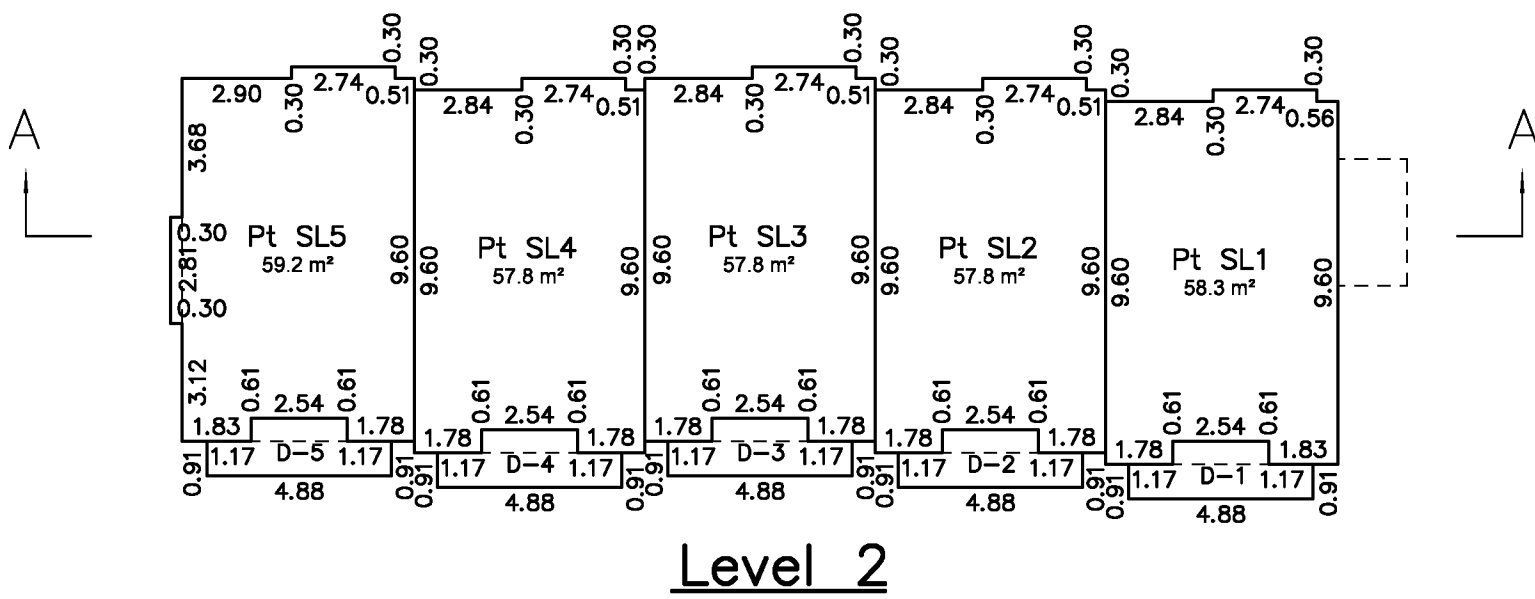
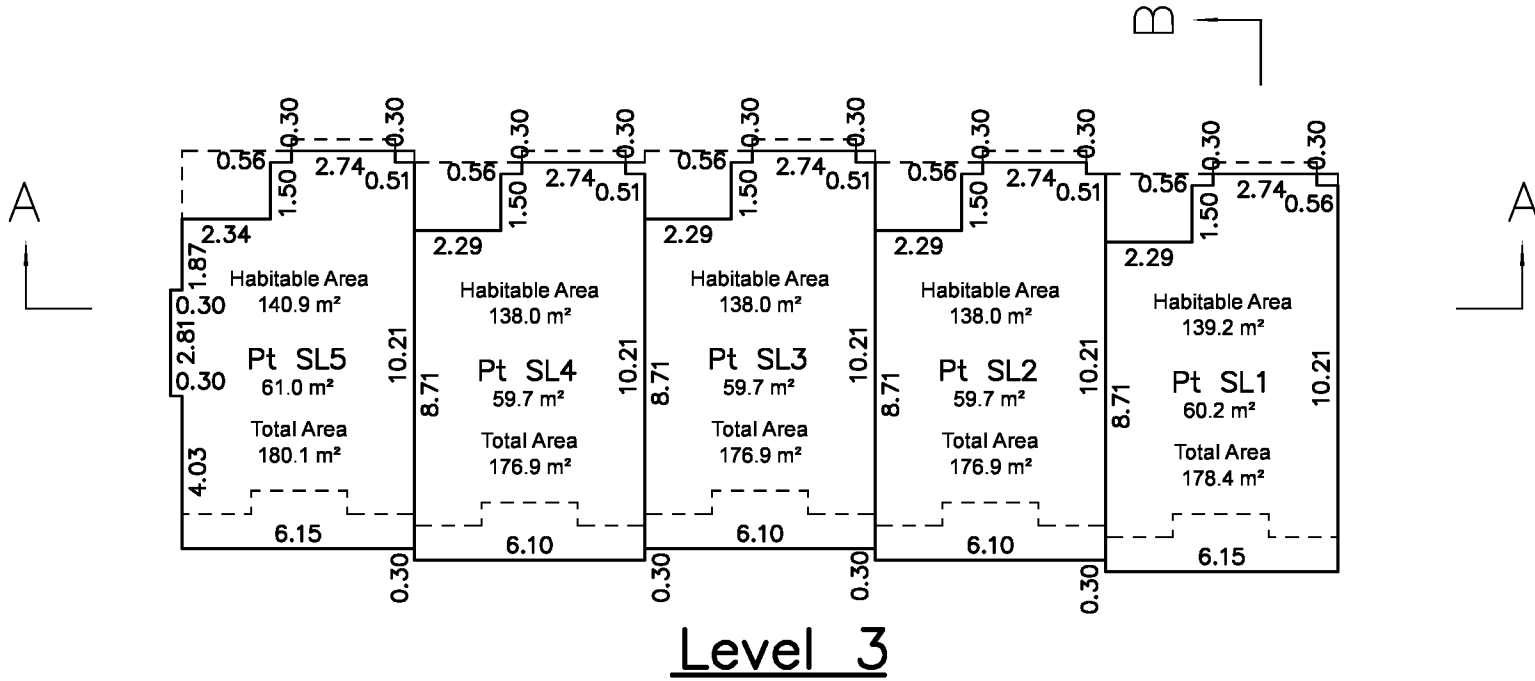
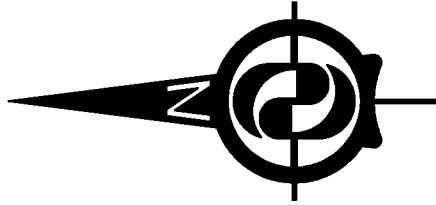

**H.Y. AND ASSOCIATES
LAND SURVEYING LTD.**

200, 9128 - 152nd STREET
SURREY, B.C.
V3R 4E7
(ph) 583-1616
File: 154271_3.DWG

GU GORDON YU, BCLS #808
DATE: APRIL 12, 2019

BUILDING 4

SCALE 1:200

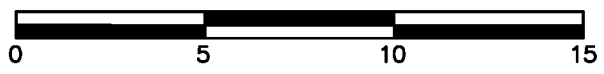

All distances are in metres.

THE INTENDED PLOT SIZE OF THIS PLAN IS 280 mm IN WIDTH BY 432 mm IN HEIGHT (B SIZE) WHEN PLOTTED AT A SCALE OF 1:200

----- PERIMETER OF FLOOR BELOW

PHASE 1 STRATA PLAN EPS5866

SHEET 4 OF 8 SHEETS

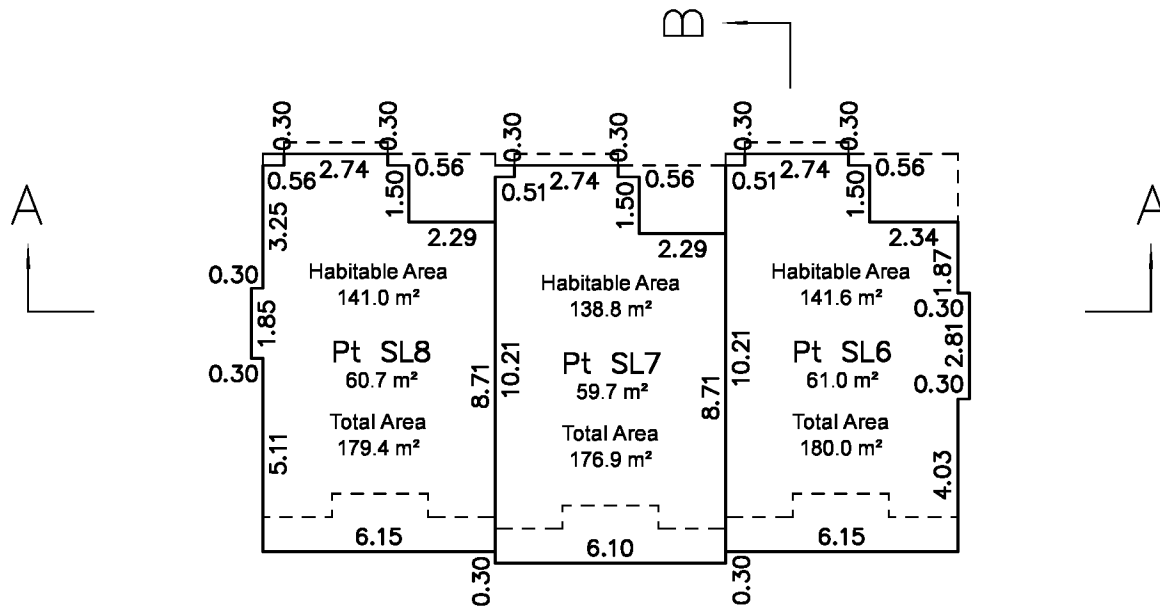
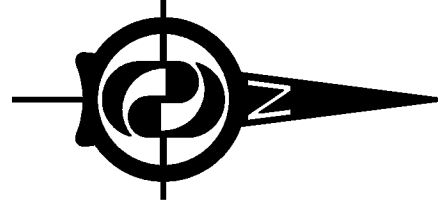

Level 3

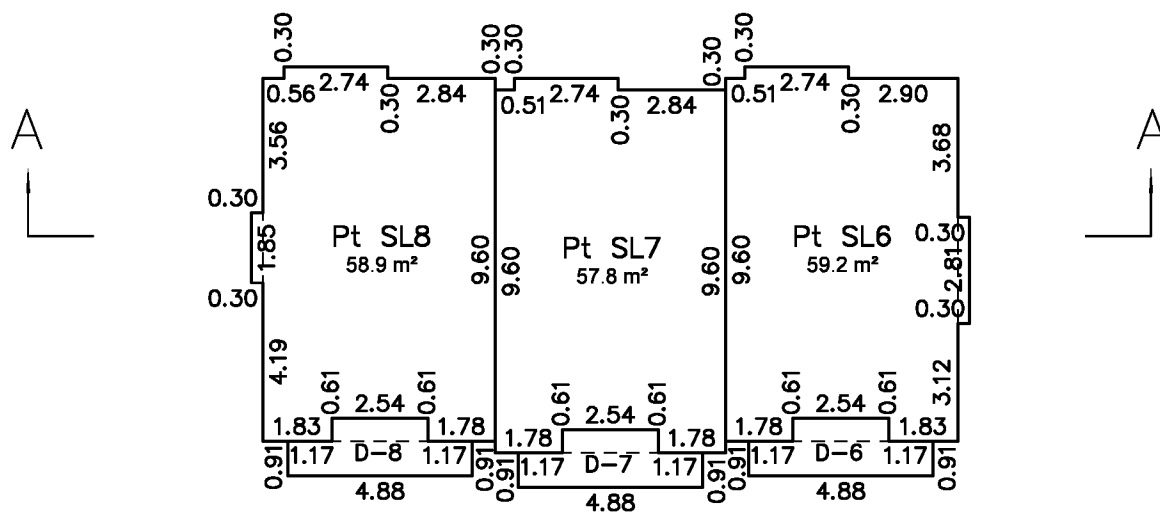

Level 2

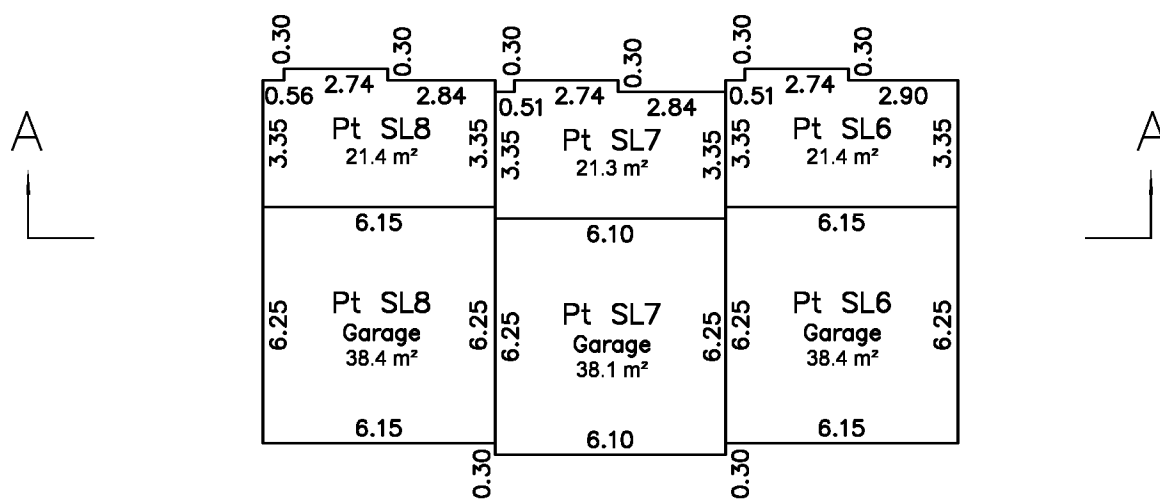

Level 1

**H.Y. AND ASSOCIATES
LAND SURVEYING LTD.**

200, 9128 - 152nd STREET
SURREY, B.C.
V3R 4E7
(ph) 583-1616
File: 154271_4.DWG

GU GORDON YU, BCLS #808
DATE: APRIL 12, 2019

BUILDING 7

SCALE 1:200

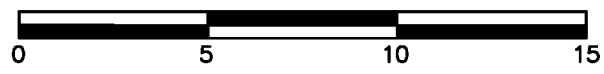

All distances are in metres.

THE INTENDED PLOT SIZE OF THIS PLAN IS 280 mm IN WIDTH BY 432 mm IN HEIGHT (B SIZE) WHEN PLOTTED AT A SCALE OF 1:200

----- PERIMETER OF FLOOR BELOW

PHASE 1 STRATA PLAN EPS5866

SHEET 5 OF 8 SHEETS

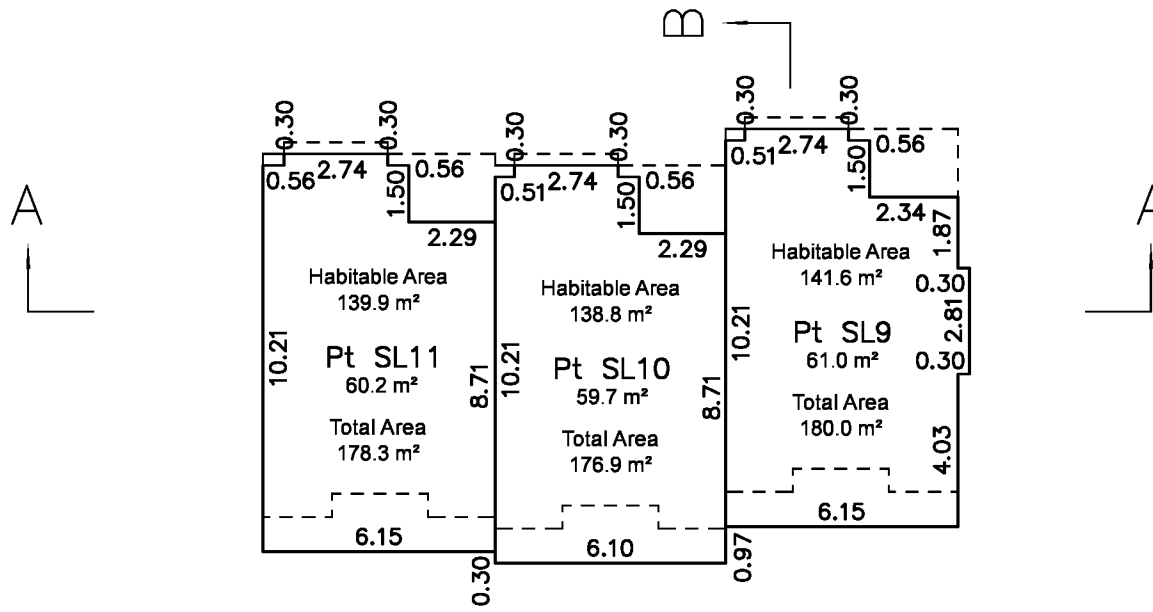
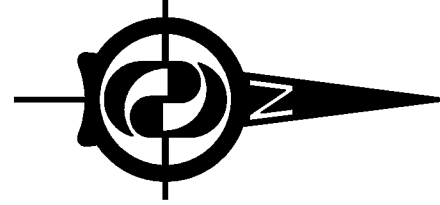

Level 3

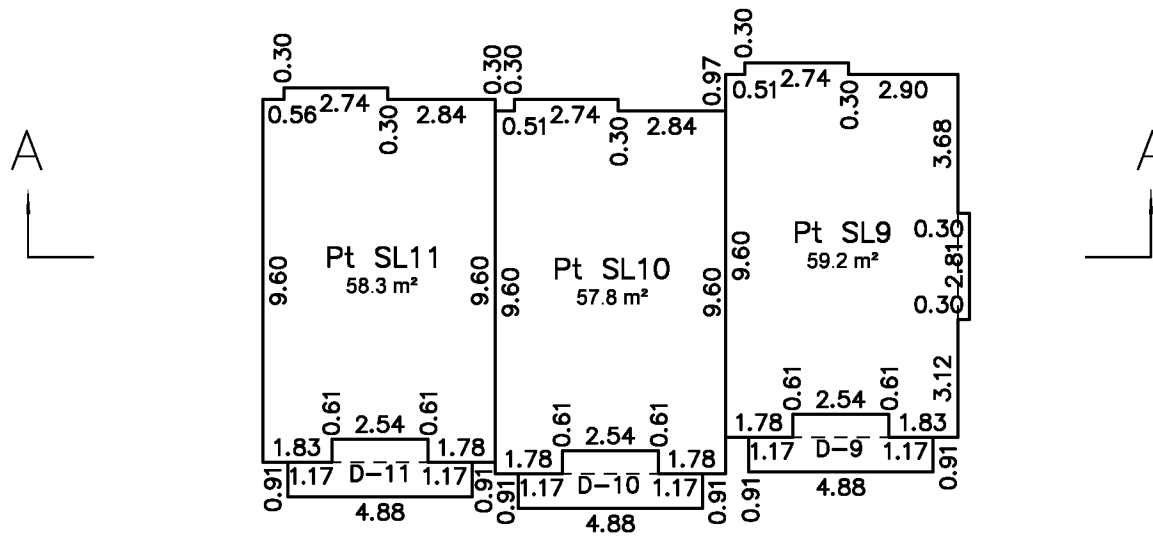

Level 2

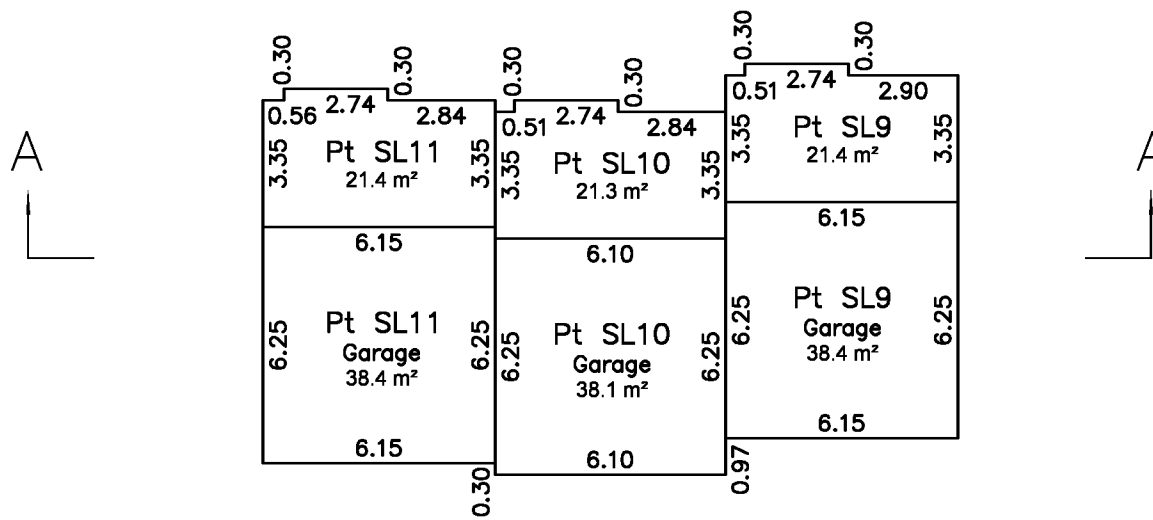

Level 1

**H.Y. AND ASSOCIATES
LAND SURVEYING LTD.**

200, 9128 - 152nd STREET
SURREY, B.C.
V3R 4E7
(ph) 583-1616
File: 154271_7.DWG

GU GORDON YU, BCLS #808
DATE: APRIL 12, 2019

CROSS SECTIONS OF BUILDING 3

SCALE 1:200



All distances are in metres.

THE INTENDED PLOT SIZE OF THIS PLAN IS 280 mm IN WIDTH BY 432 mm IN HEIGHT (B SIZE) WHEN PLOTTED AT A SCALE OF 1:200

STRATA LOT BOUNDARIES DEFINED:

- UNDERSIDE OF CONCRETE SLAB OF GROUND FLOOR
- MIDPOINT OF STRUCTURAL PORTION OF CEILING
- MIDPOINT OF STRUCTURAL PORTION OF PARTY WALLS
- OUTSIDE OF STRUCTURAL PORTION OF EXTERIOR WALLS

PHASE 1

SHEET 6 OF 8 SHEETS

STRATA PLAN EPS5866

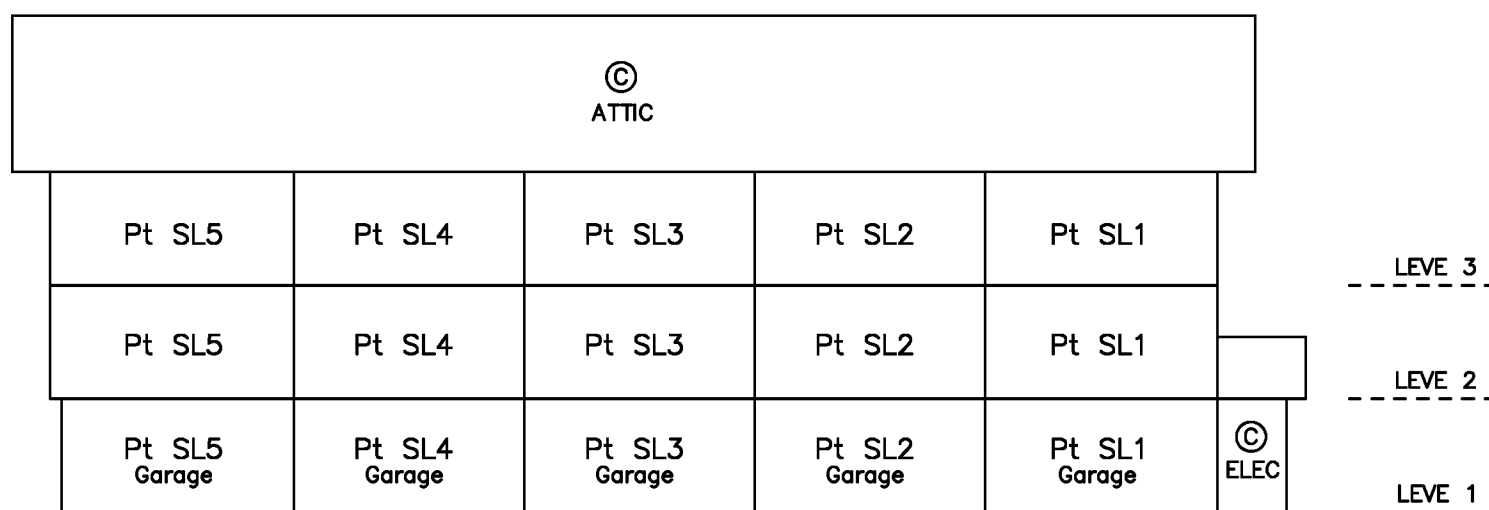

CROSS SECTION A-A

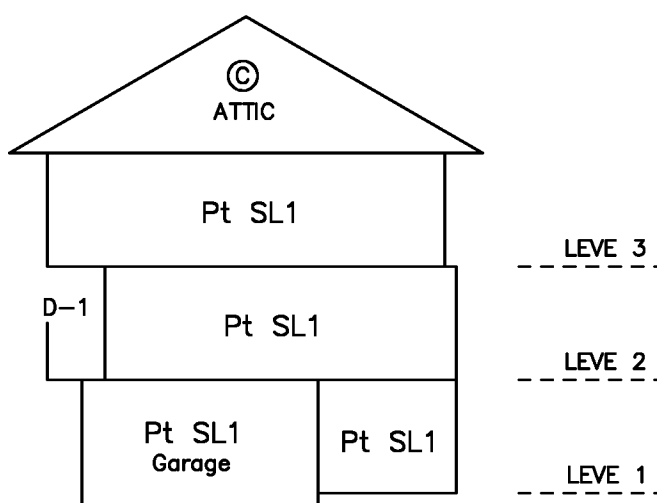

CROSS SECTION B-B

H.Y. AND ASSOCIATES LAND SURVEYING LTD.

200, 9128 - 152nd STREET
SURREY, B.C.
V3R 4E7
(ph) 583-1616

File: 154271_3_SEC.DWG

GU GORDON YU, BCLS #808
DATE: APRIL 12, 2019

CROSS SECTIONS OF BUILDING 4

PHASE 1 STRATA PLAN EPS5866

SHEET 7 OF 8 SHEETS

SCALE 1:200

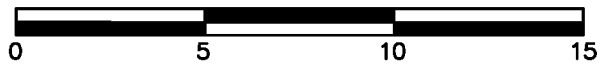

All distances are in metres.

THE INTENDED PLOT SIZE OF THIS PLAN IS 280 mm IN WIDTH BY 432 mm IN HEIGHT (B SIZE) WHEN PLOTTED AT A SCALE OF 1:200

STRATA LOT BOUNDARIES DEFINED:

- UNDERSIDE OF CONCRETE SLAB OF GROUND FLOOR
- MIDPOINT OF STRUCTURAL PORTION OF CEILING
- MIDPOINT OF STRUCTURAL PORTION OF PARTY WALLS
- OUTSIDE OF STRUCTURAL PORTION OF EXTERIOR WALLS

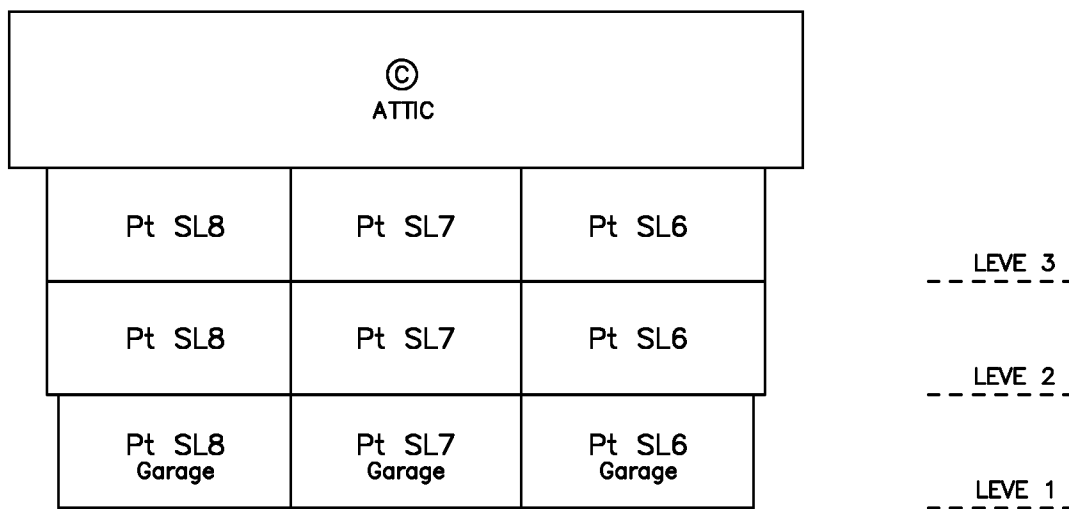

CROSS SECTION A-A

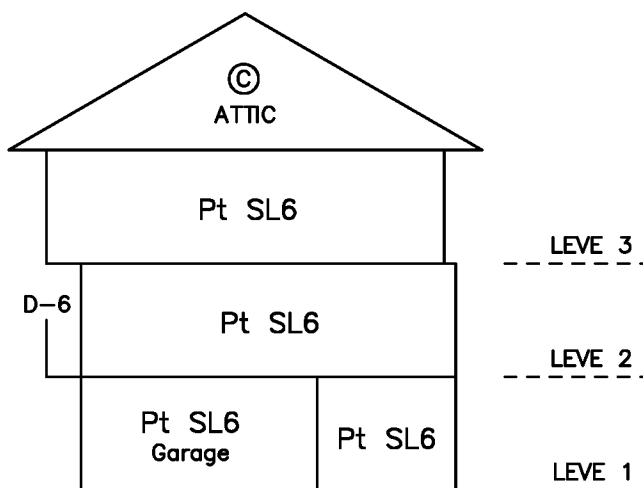

CROSS SECTION B-B

H.Y. AND ASSOCIATES LAND SURVEYING LTD.

200, 9128 - 152nd STREET
 SURREY, B.C.
 V3R 4E7
 (ph) 583-1616
 File: 154271_4_SEC.DWG

GU GORDON YU, BCLS #808
 DATE: APRIL 12, 2019

CROSS SECTIONS OF BUILDING 7

PHASE 1 SHEET 8 OF 8 SHEETS STRATA PLAN EPS5866

SCALE 1:200



All distances are in metres.

THE INTENDED PLOT SIZE OF THIS PLAN IS 280 mm IN WIDTH BY 432 mm IN HEIGHT (B SIZE) WHEN PLOTTED AT A SCALE OF 1:200

STRATA LOT BOUNDARIES DEFINED:

- UNDERSIDE OF CONCRETE SLAB OF GROUND FLOOR
- MIDPOINT OF STRUCTURAL PORTION OF CEILING
- MIDPOINT OF STRUCTURAL PORTION OF PARTY WALLS
- OUTSIDE OF STRUCTURAL PORTION OF EXTERIOR WALLS

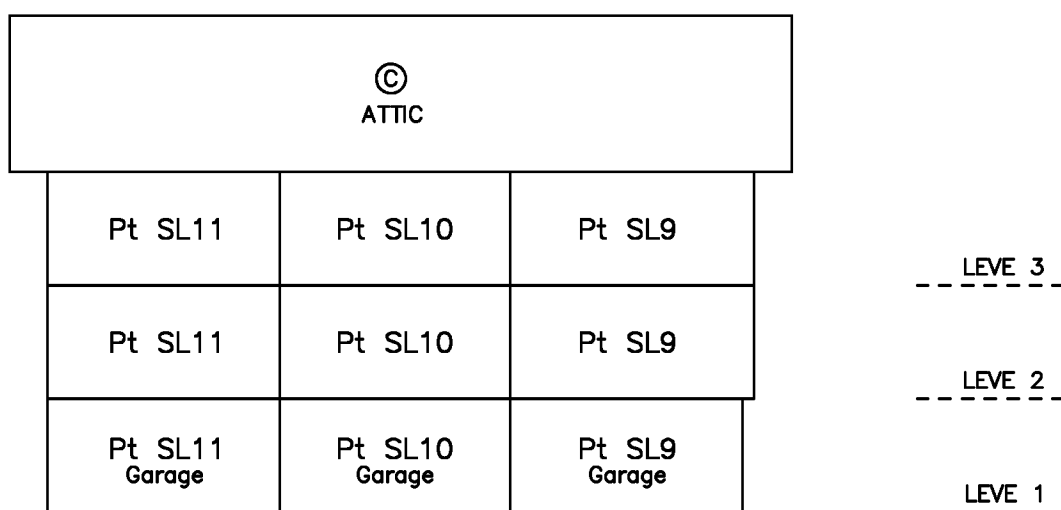

CROSS SECTION A-A

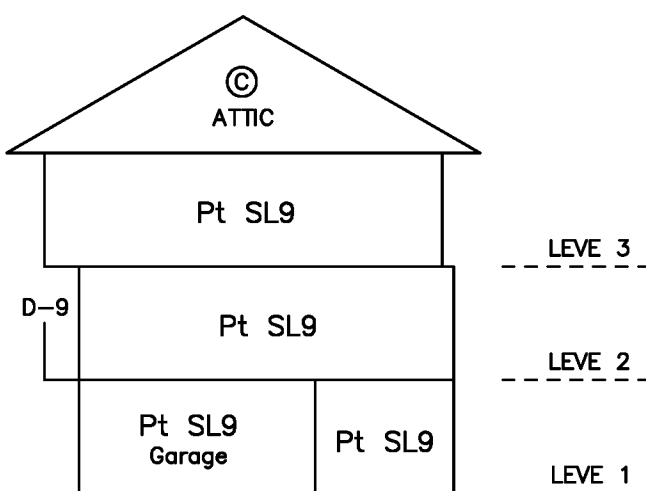

CROSS SECTION B-B

**H.Y. AND ASSOCIATES
LAND SURVEYING LTD.**

200, 9128 - 152nd STREET
SURREY, B.C.
V3R 4E7
(ph) 583-1616

File: 154271_7_SEC.DWG

GU GORDON YU, BCLS #808
DATE: APRIL 12, 2019

**STRATA PLAN OF PART OF LOT 1
SECTION 7 TOWNSHIP 2
NEW WESTMINSTER DISTRICT PLAN EPP73003
EXCEPT PHASE 1 STRATA PLAN EPS5866**

PHASE TWO SHEET 1 OF 6 SHEETS
STRATA PLAN EPS5866

BCGS 92G.016

SCALE 1:750



ALL DIMENSIONS ARE IN METRES

THE INTENDED PLOT SIZE OF THIS PLAN IS 280 mm IN WIDTH BY 432 mm IN HEIGHT (B SIZE) WHEN PLOTTED AT A SCALE OF 1:750

INTEGRATED SURVEY AREA NO. 1, SURREY, BC, NAD83 (CSRS) 4.0.0.BC.1.GVRD.

GRID BEARINGS ARE DERIVED FROM OBSERVATIONS BETWEEN GEODETIC CONTROL MONUMENTS 5592 AND 5231 AND ARE REFERRED TO THE CENTRAL MERIDIAN OF UTM ZONE 10

THE UTM COORDINATES AND ESTIMATED HORIZONTAL POSITIONAL ACCURACY ACHIEVED ARE DERIVED FROM THE MASCOT PUBLISHED COORDINATES AND STANDARD DEVIATIONS FOR GEODETIC CONTROL MONUMENTS 5592 AND 5231

THIS PLAN SHOWS HORIZONTAL GROUND-LEVEL DISTANCES UNLESS OTHERWISE SPECIFIED. TO COMPUTE GRID DISTANCES, MULTIPLY GROUND-LEVEL DISTANCES BY THE AVERAGE COMBINED FACTOR OF 0.9995958 WHICH HAS BEEN DERIVED FROM GEODETIC CONTROL MONUMENTS 5592 AND 5231

LEGEND

- ⊕ INDICATES CONTROL MONUMENT FOUND
- INDICATES STANDARD IRON POST FOUND
- ⊙ INDICATES COMMON PROPERTY
- ELEC INDICATES ELECTRICAL CLOSET
- D INDICATES DECK
- PK INDICATES PARKING
- PT INDICATES PART

5592
UTM Zone 10 coordinates
Datum: NAD83(CSRS) 4.0.0.BC.1.GVRD.
UTM easting: 507998.428
UTM northing: 5439478.491
Point combined factor: 0.9995957
Estimated Horizontal Positional Accuracy: 0.02m

5231
UTM Zone 10 coordinates
Datum: NAD83(CSRS) 4.0.0.BC.1.GVRD.
UTM easting: 507998.997
UTM northing: 5439222.540
Point combined factor: 0.9995960
Estimated Horizontal Positional Accuracy: 0.02m

THE COMMON FACILITY AMENITY BUILDING IN THIS PHASE IS SUBJECT TO THE CONDITIONS SET OUT IN THE FORM P FILED FOR THIS STRATA PLAN

STRATA LOT MEASUREMENTS ARE 90° OR 45° UNLESS NOTED OTHERWISE.
STRATA LOT DIMENSIONS ARE MEASURED TO:
- OUTSIDE OF EXTERIOR STRUCTURAL WALLS
- CENTERLINE OF PARTY WALLS

DECK AND PARKING AREAS ARE LIMITED COMMON PROPERTIES FOR THE USE OF THE STRATA LOT INDICATED (eg: D-12, PK-12)

DECK AND PARKING AREAS ARE DEFINED AS TO HEIGHT BY THE CENTRE OF THE FLOOR ABOVE OR ITS EXTENSIONS, OR WHERE THERE IS NO FLOOR ABOVE BY THE AVERAGE HEIGHT OF STRATA LOTS WITHIN THE SAME BUILDING, UNLESS OTHERWISE NOTED.

**H.Y. AND ASSOCIATES
LAND SURVEYING LTD.**

200, 9128 - 152 STREET
SURREY, B.C.
V3R 4E7
(ph) 583-1616

File: 154271_PH2_PG1.DWG

THIS PLAN IS PHASE 2 OF A 3 PHASE STRATA PLAN UNDER SECTION 224 OF THE STRATA PROPERTY ACT LYING WITHIN THE JURISDICTION OF THE APPROVING OFFICER FOR CITY OF SURREY

THIS PLAN LIES WITHIN THE METRO VANCOUVER REGIONAL DISTRICT - CITY OF SURREY

THE BUILDINGS INCLUDED IN THIS STRATA PLAN HAVE NOT BEEN PREVIOUSLY OCCUPIED.

THE BUILDINGS SHOWN ON THIS STRATA PLAN ARE WITHIN THE EXTERNAL BOUNDARIES OF THE LAND THAT IS THE SUBJECT OF THE STRATA PLAN.

THE FIELD SURVEY REPRESENTED BY THIS PLAN WAS COMPLETED ON THE 16th DAY OF APRIL, 2019
GU GORDON YU, BCLS #808



CIVIC ADDRESS:

12073 62nd AVENUE
SURREY, BC

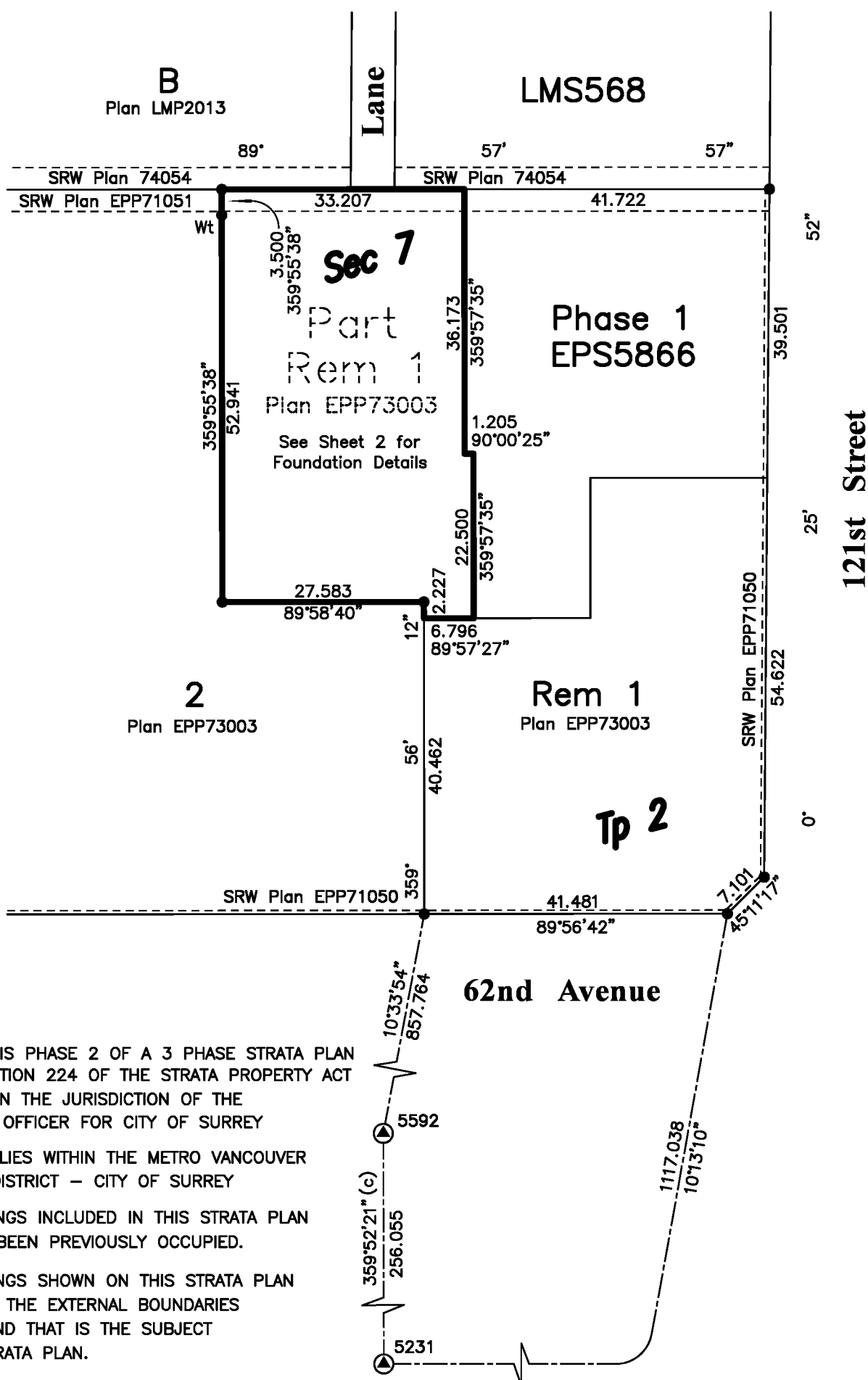

FOUNDATION DETAILS

PHASE 2 STRATA PLAN EPS5866

SHEET 2 OF 6 SHEETS

SCALE 1:250



All distances are in metres.

THE INTENDED PLOT SIZE OF THIS PLAN IS 280 mm IN WIDTH BY 432 mm IN HEIGHT (B SIZE) WHEN PLOTTED AT A SCALE OF 1:250

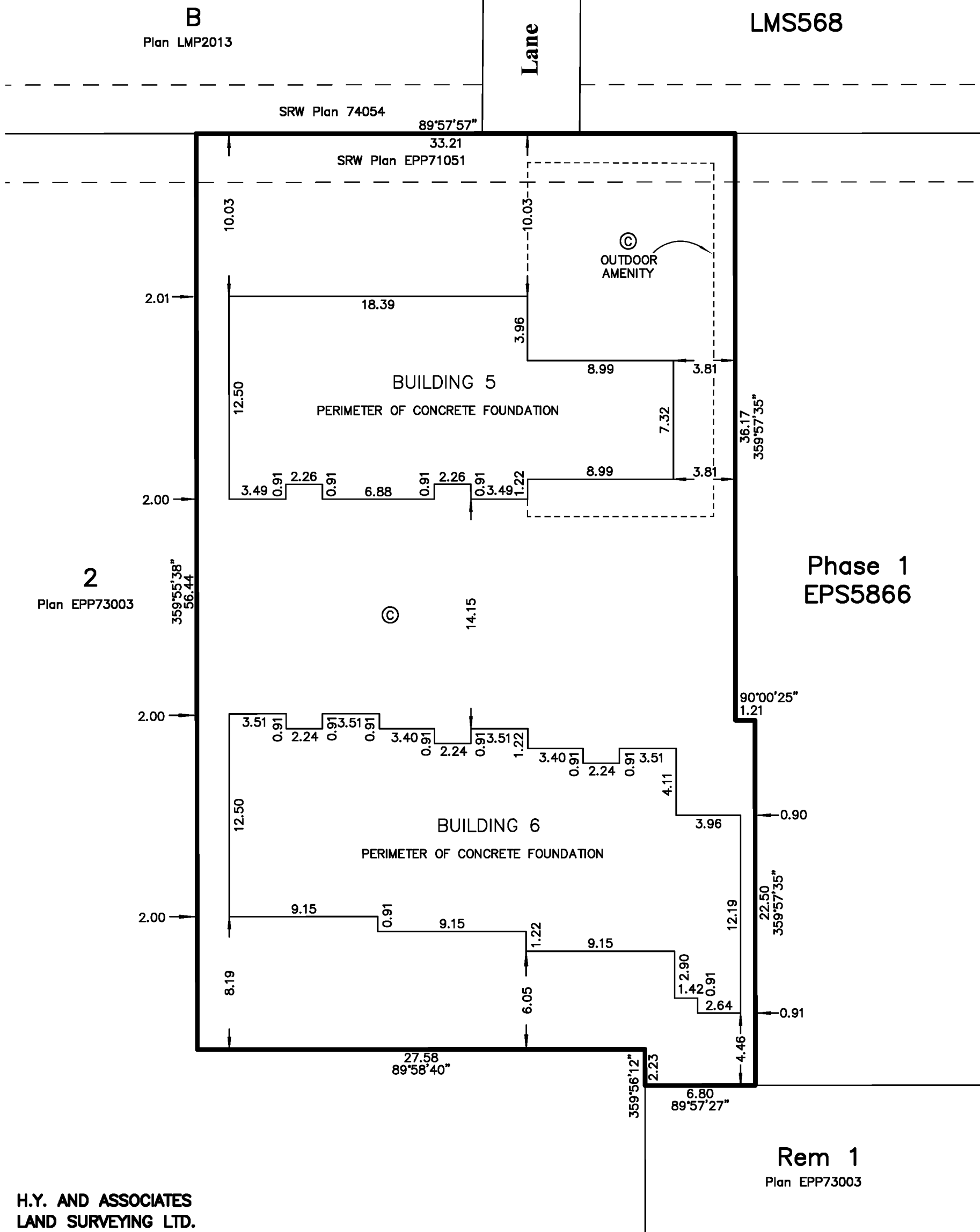
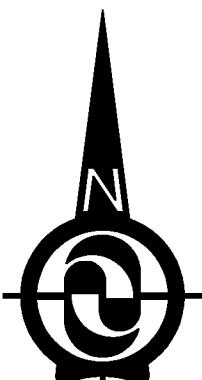

**H.Y. AND ASSOCIATES
LAND SURVEYING LTD.**

200, 9128 - 152nd STREET
SURREY, B.C.
V3R 4E7
(ph) 583-1616
File: 154271_PH2_PG2.DWG

Rem 1
Plan EPP73003

GU GORDON YU, BCLS #808
DATE: APRIL 16, 2019

BUILDING 5

SCALE 1:200

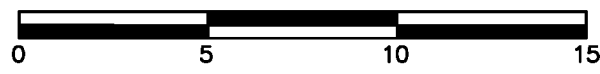

All distances are in metres.

THE INTENDED PLOT SIZE OF THIS PLAN IS 280 mm IN WIDTH BY 432 mm IN HEIGHT (B SIZE) WHEN PLOTTED AT A SCALE OF 1:200

----- PERIMETER OF FLOOR BELOW

PHASE 2 STRATA PLAN EPS5866

SHEET 3 OF 6 SHEETS

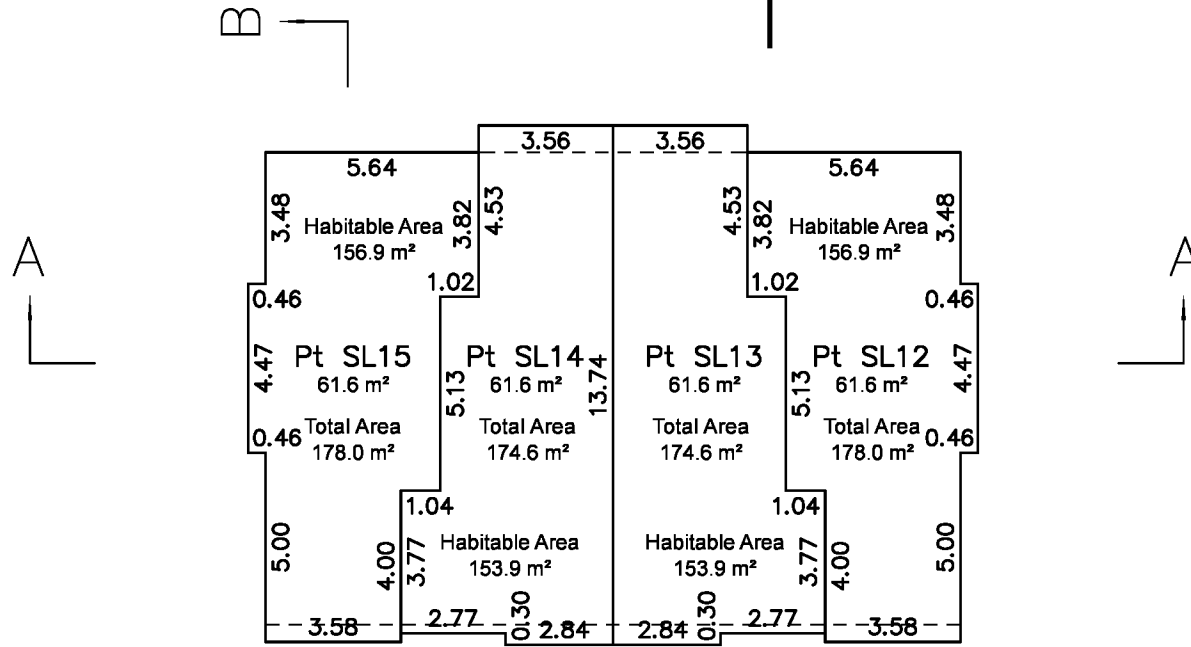
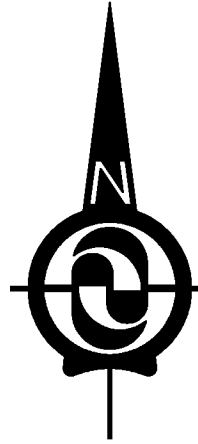

Level 3

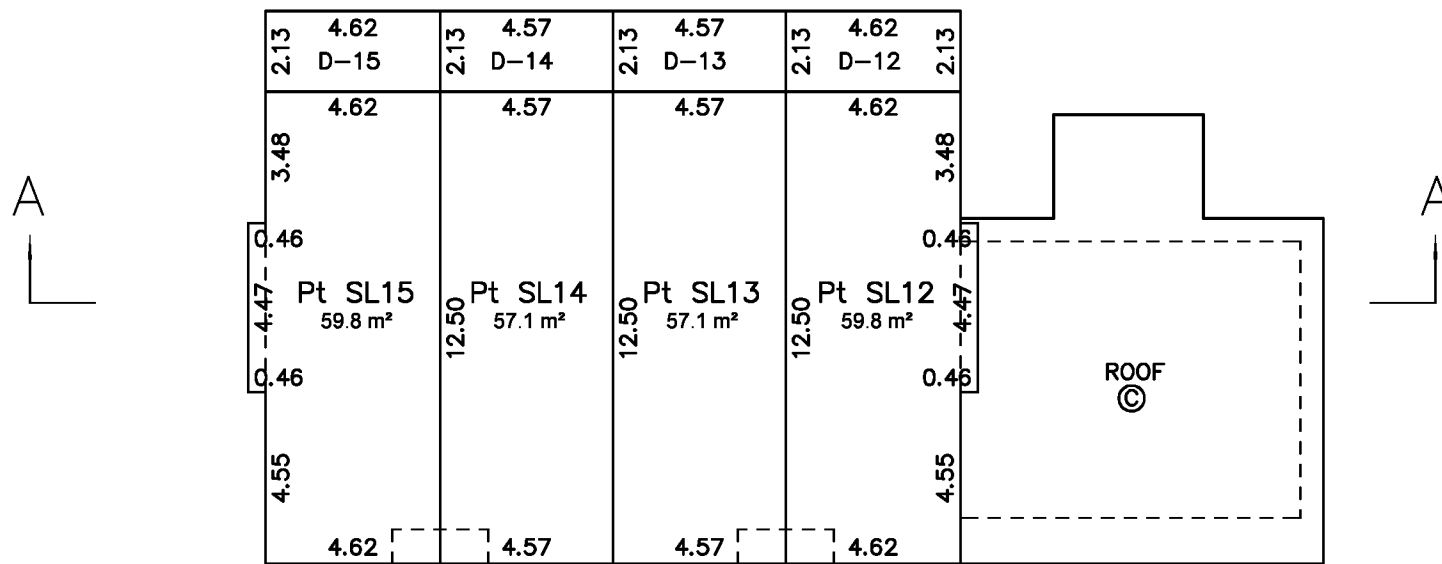

Level 2

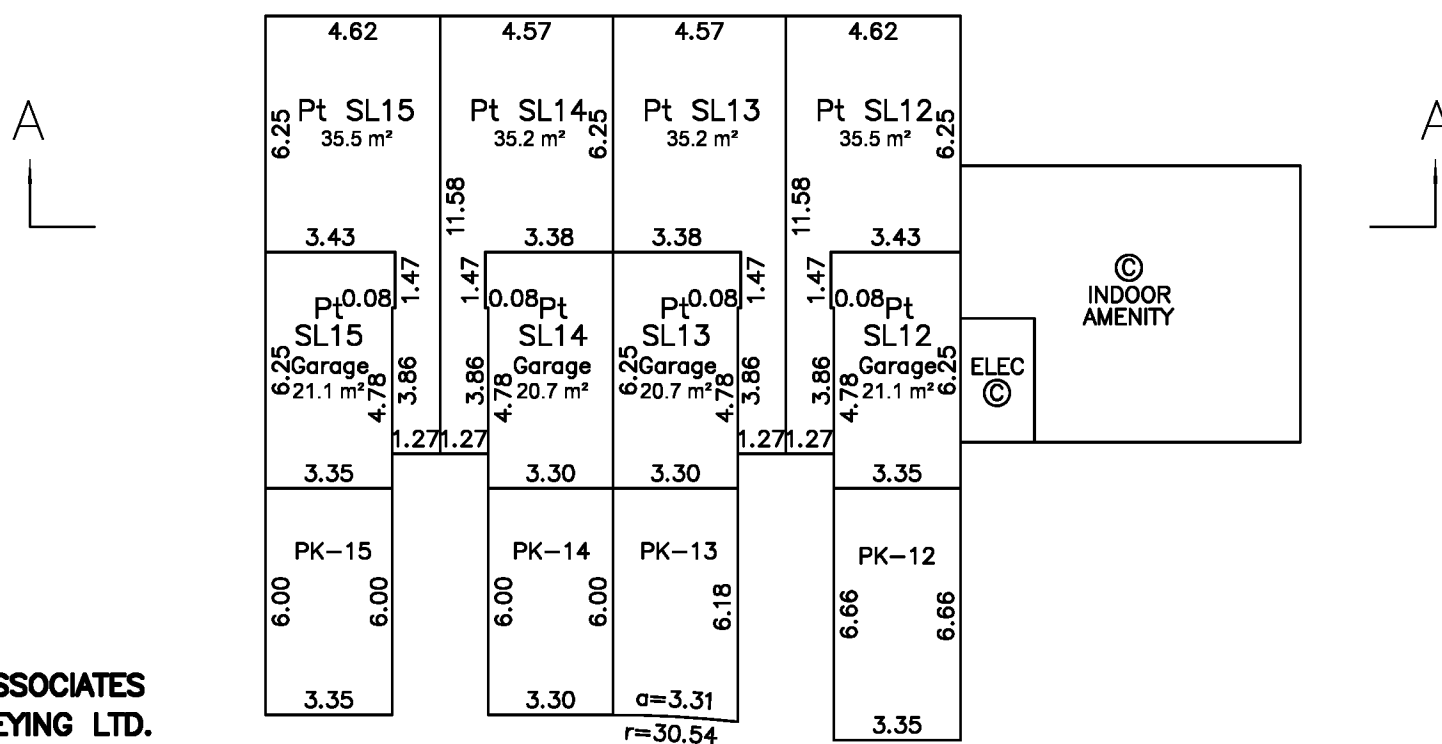

Level 1

**H.Y. AND ASSOCIATES
LAND SURVEYING LTD.**

200, 9128 - 152nd STREET
SURREY, B.C.
V3R 4E7
(ph) 583-1616
File: 154271_5.DWG

GU GORDON YU, BCLS #808
DATE: APRIL 16, 2019

BUILDING 6

SCALE 1:200



All distances are in metres.

THE INTENDED PLOT SIZE OF THIS PLAN IS 280 mm IN WIDTH BY 432 mm IN HEIGHT (B SIZE) WHEN PLOTTED AT A SCALE OF 1:200

----- PERIMETER OF FLOOR BELOW

PHASE 2 STRATA PLAN EPS5866

SHEET 4 OF 6 SHEETS

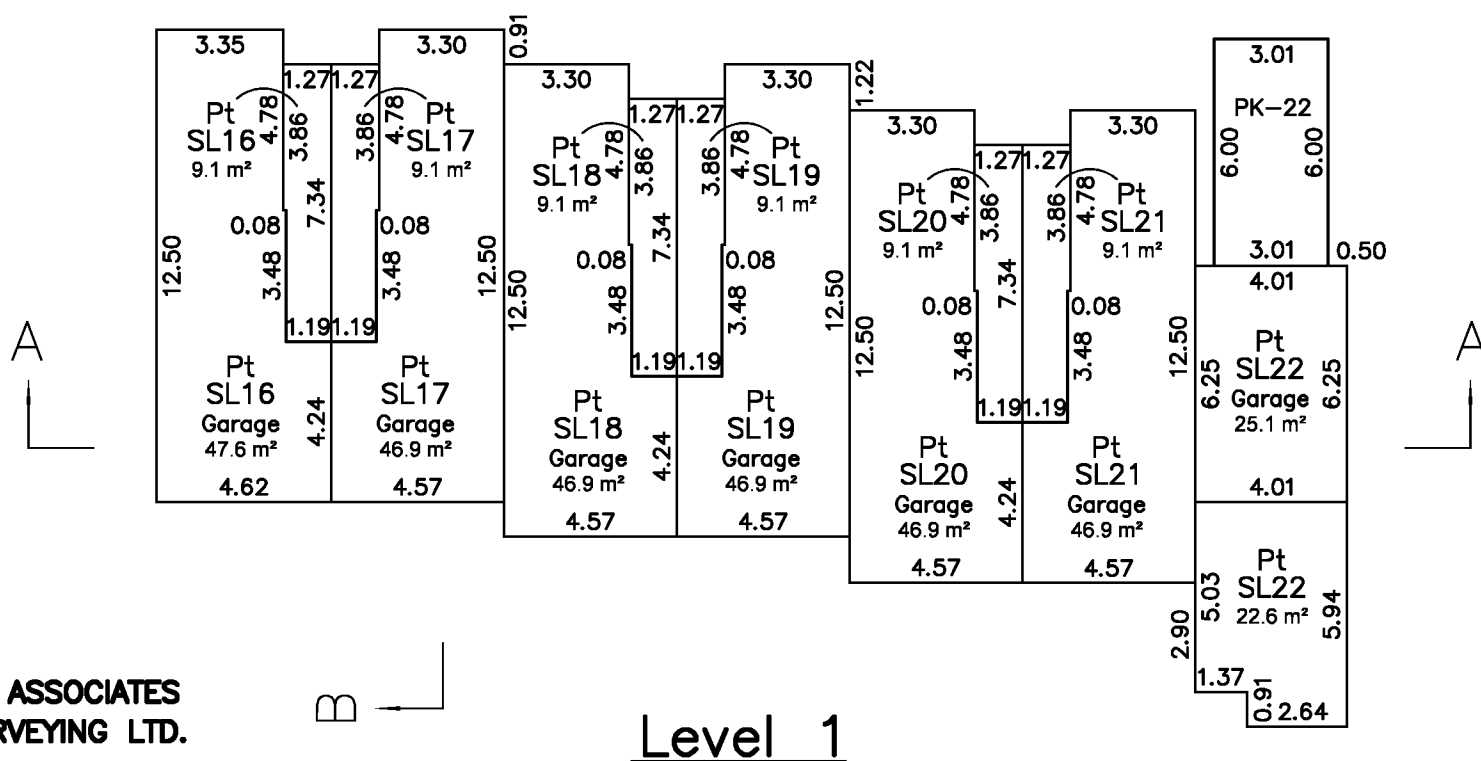
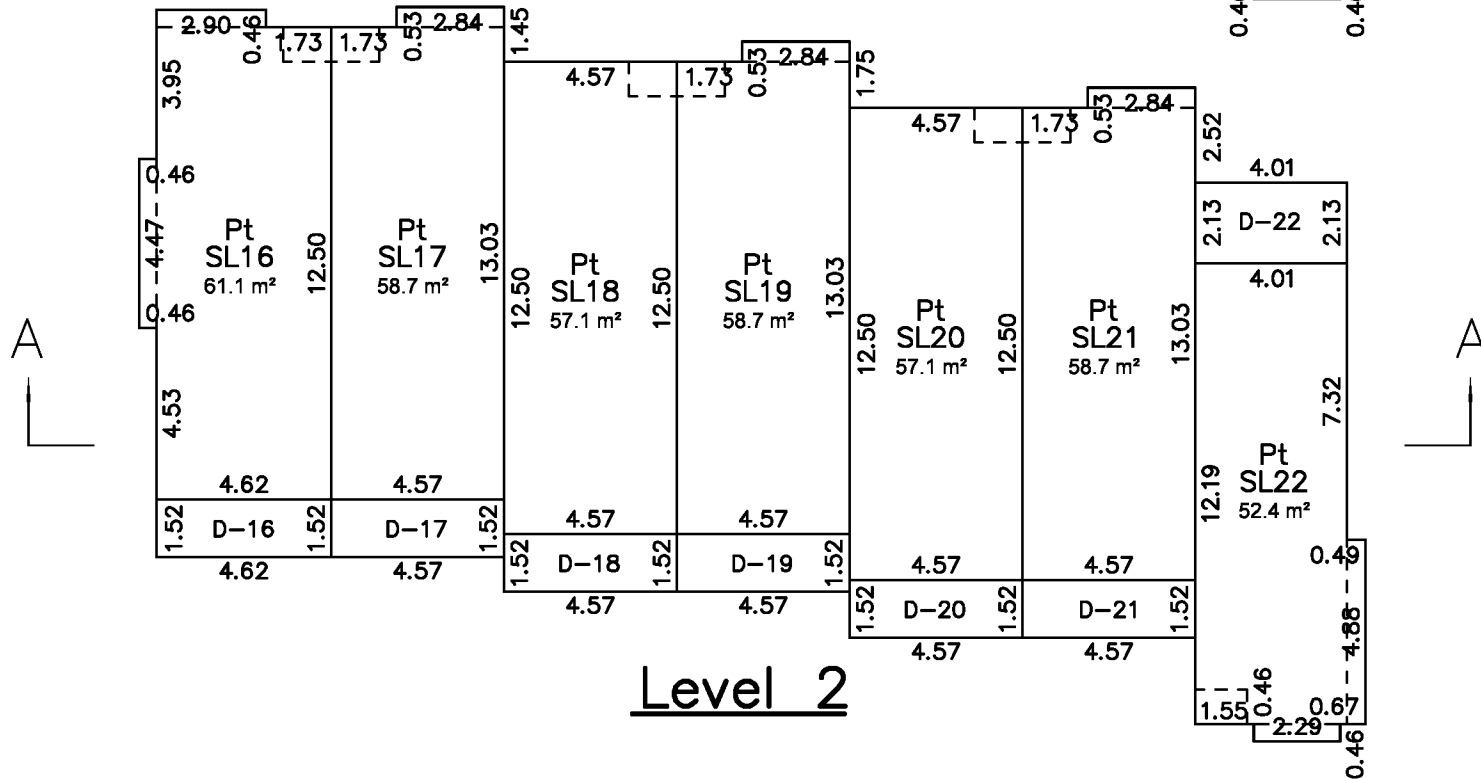
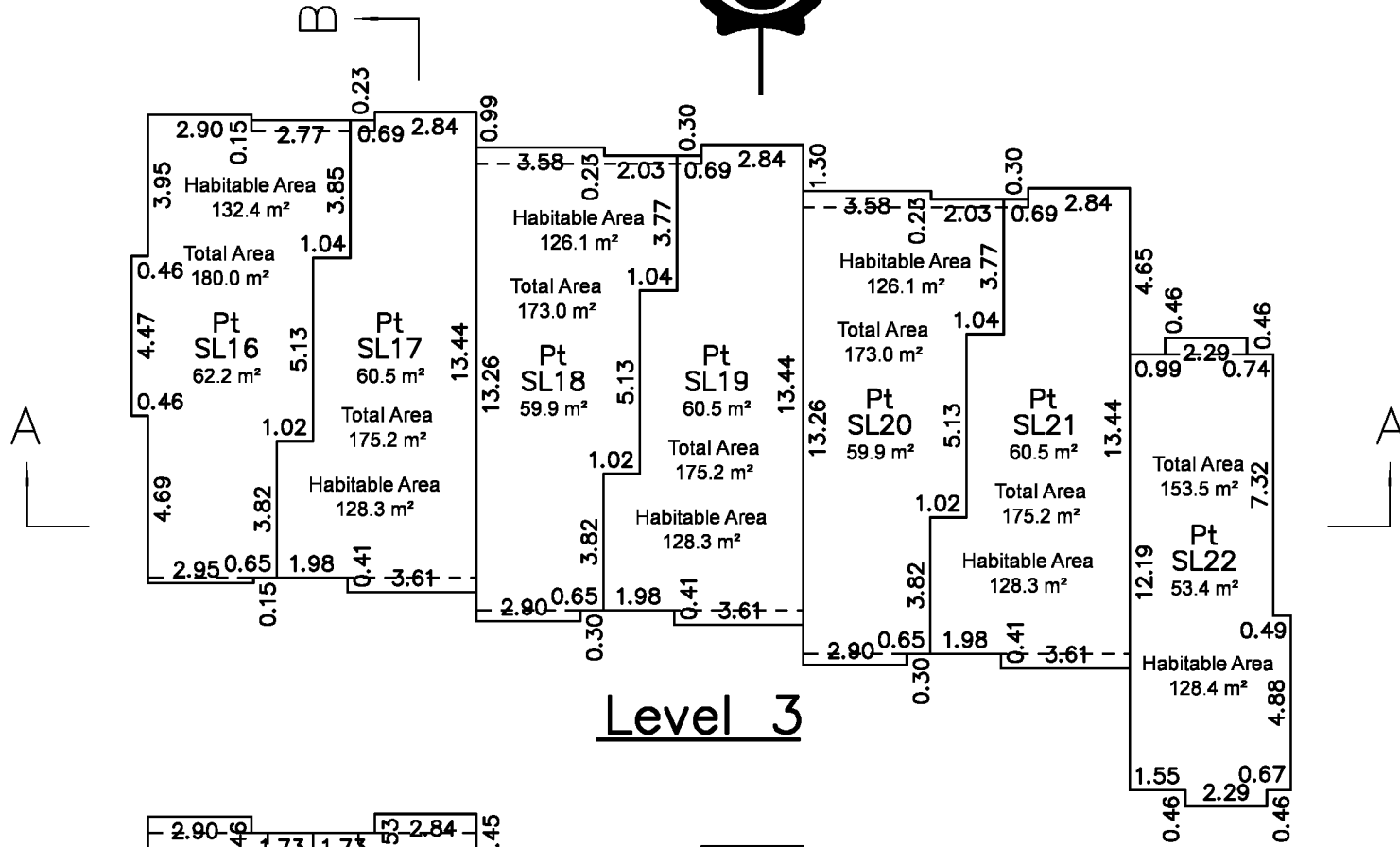
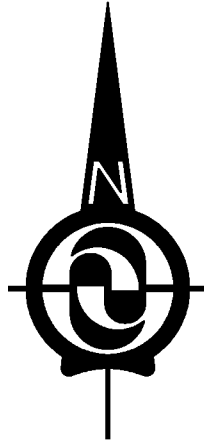

**H.Y. AND ASSOCIATES
LAND SURVEYING LTD.**

200, 9128 - 152nd STREET
SURREY, B.C.
V3R 4E7
(ph) 583-1616
File: 154271_6.DWG

GU GORDON YU, BCLS #808
DATE: APRIL 16, 2019

CROSS SECTIONS OF BUILDING 5

PHASE 2 STRATA PLAN EPS5866

SHEET 5 OF 6 SHEETS

SCALE 1:200



All distances are in metres.

THE INTENDED PLOT SIZE OF THIS PLAN IS 280 mm IN WIDTH BY 432 mm IN HEIGHT (B SIZE) WHEN PLOTTED AT A SCALE OF 1:200

STRATA LOT BOUNDARIES DEFINED:

- UNDERSIDE OF CONCRETE SLAB OF GROUND FLOOR
- MIDPOINT OF STRUCTURAL PORTION OF CEILING
- MIDPOINT OF STRUCTURAL PORTION OF PARTY WALLS
- OUTSIDE OF STRUCTURAL PORTION OF EXTERIOR WALLS

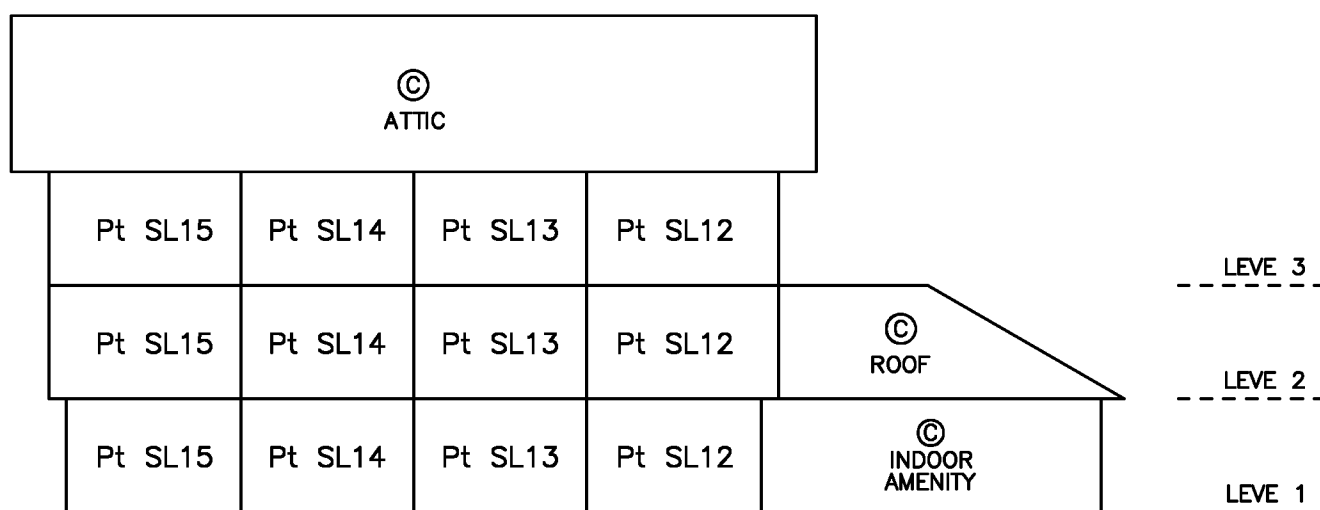

CROSS SECTION A-A

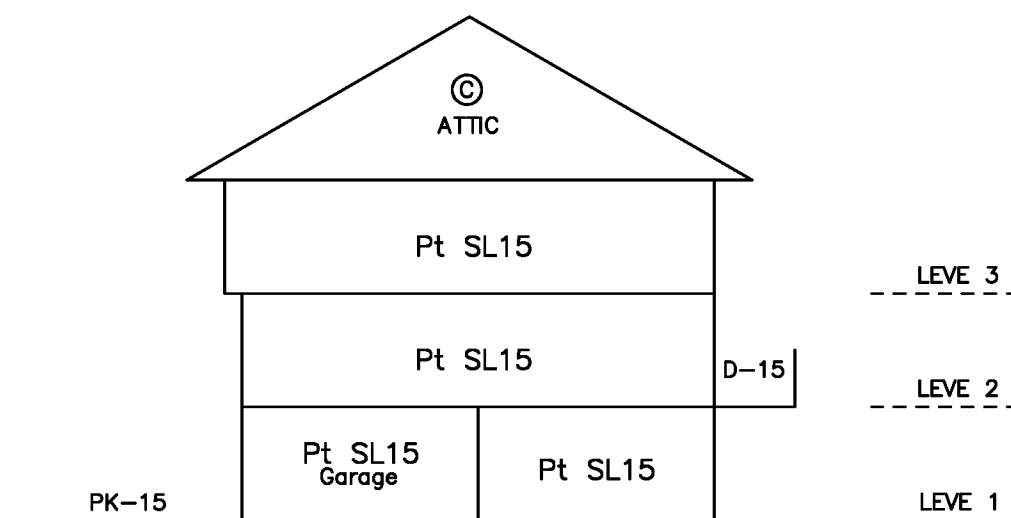

CROSS SECTION B-B

H.Y. AND ASSOCIATES LAND SURVEYING LTD.

200, 9128 - 152nd STREET
 SURREY, B.C.
 V3R 4E7
 (ph) 583-1616
 File: 154271_5_SEC.DWG

GU GORDON YU, BCLS #808
 DATE: APRIL 16, 2019

CROSS SECTIONS OF BUILDING 6

PHASE 2 STRATA PLAN EPS5866

SHEET 6 OF 6 SHEETS

SCALE 1:200



All distances are in metres.

THE INTENDED PLOT SIZE OF THIS PLAN IS 280 mm IN WIDTH BY 432 mm IN HEIGHT (B SIZE) WHEN PLOTTED AT A SCALE OF 1:200

STRATA LOT BOUNDARIES DEFINED:

- UNDERSIDE OF CONCRETE SLAB OF GROUND FLOOR
- MIDPOINT OF STRUCTURAL PORTION OF CEILING
- MIDPOINT OF STRUCTURAL PORTION OF PARTY WALLS
- OUTSIDE OF STRUCTURAL PORTION OF EXTERIOR WALLS

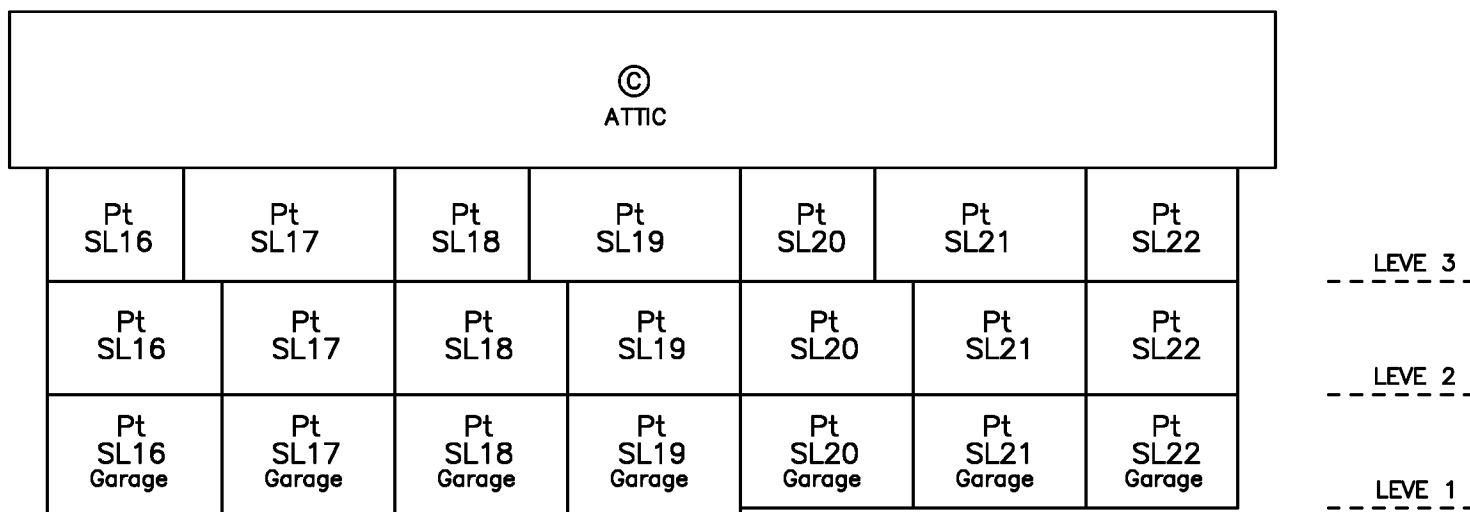

CROSS SECTION A-A

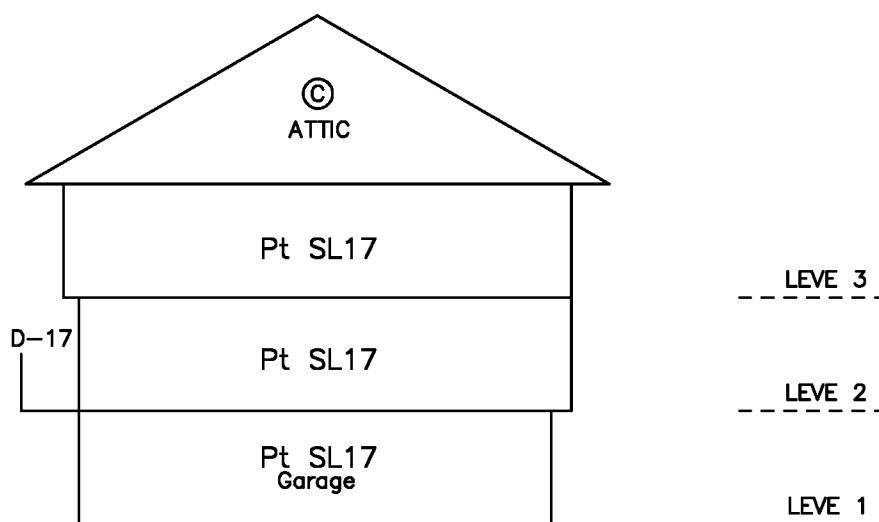

CROSS SECTION B-B

**H.Y. AND ASSOCIATES
LAND SURVEYING LTD.**

200, 9128 - 152nd STREET
SURREY, B.C.
V3R 4E7
(ph) 583-1616

File: 154271_6_SEC.DWG

GU GORDON YU, BCLS #808
DATE: APRIL 16, 2019

**STRATA PLAN OF LOT 1
SECTION 7 TOWNSHIP 2
NEW WESTMINSTER DISTRICT PLAN EPP73003
EXCEPT PHASES 1 AND 2 STRATA PLAN EPS5866**

PHASE THREE SHEET 1 OF 8 SHEETS
STRATA PLAN EPS5866

BCGS 92G.016

SCALE 1:750



ALL DIMENSIONS ARE IN METRES

THE INTENDED PLOT SIZE OF THIS PLAN IS 280 mm IN WIDTH BY 432 mm IN HEIGHT (B SIZE) WHEN PLOTTED AT A SCALE OF 1:750

INTEGRATED SURVEY AREA NO. 1, SURREY, BC, NAD83 (CSRS) 4.0.0.BC.1.GVRD.

GRID BEARINGS ARE DERIVED FROM OBSERVATIONS BETWEEN GEODETIC CONTROL MONUMENTS 5592 AND 5231 AND ARE REFERRED TO THE CENTRAL MERIDIAN OF UTM ZONE 10

THE UTM COORDINATES AND ESTIMATED HORIZONTAL POSITIONAL ACCURACY ACHIEVED ARE DERIVED FROM THE MASCOT PUBLISHED COORDINATES AND STANDARD DEVIATIONS FOR GEODETIC CONTROL MONUMENTS 5592 AND 5231

THIS PLAN SHOWS HORIZONTAL GROUND-LEVEL DISTANCES UNLESS OTHERWISE SPECIFIED. TO COMPUTE GRID DISTANCES, MULTIPLY GROUND-LEVEL DISTANCES BY THE AVERAGE COMBINED FACTOR OF 0.9995958 WHICH HAS BEEN DERIVED FROM GEODETIC CONTROL MONUMENTS 5592 AND 5231



CIVIC ADDRESS:

12073 62nd AVENUE
SURREY, BC

LEGEND

- ⊕ INDICATES CONTROL MONUMENT FOUND
- INDICATES STANDARD IRON POST FOUND
- ⊙ INDICATES COMMON PROPERTY
- ELEC INDICATES ELECTRICAL CLOSET
- D INDICATES DECK
- PK INDICATES PARKING
- PT INDICATES PART

5592
UTM Zone 10 coordinates
Datum: NAD83(CSRS) 4.0.0.BC.1.GVRD.
UTM easting: 507998.428
UTM northing: 5439478.491
Point combined factor: 0.9995957
Estimated Horizontal Positional Accuracy: 0.02m

5231
UTM Zone 10 coordinates
Datum: NAD83(CSRS) 4.0.0.BC.1.GVRD.
UTM easting: 507998.997
UTM northing: 5439222.540
Point combined factor: 0.9995960
Estimated Horizontal Positional Accuracy: 0.02m

STRATA LOT MEASUREMENTS ARE 90° OR 45° UNLESS NOTED OTHERWISE.
STRATA LOT DIMENSIONS ARE MEASURED TO:
- OUTSIDE OF EXTERIOR STRUCTURAL WALLS
- CENTERLINE OF PARTY WALLS

DECK AND PARKING AREAS ARE LIMITED COMMON PROPERTIES FOR THE USE OF THE STRATA LOT INDICATED (eg: D-23, PK-31)

DECK AND PARKING AREAS ARE DEFINED AS TO HEIGHT BY THE CENTRE OF THE FLOOR ABOVE OR ITS EXTENSIONS, OR WHERE THERE IS NO FLOOR ABOVE BY THE AVERAGE HEIGHT OF STRATA LOTS WITHIN THE SAME BUILDING, UNLESS OTHERWISE NOTED.

**H.Y. AND ASSOCIATES
LAND SURVEYING LTD.**
200, 9128 - 152 STREET
SURREY, B.C.
V3R 4E7
(ph) 583-1616
File: 154271_PH3_PG1.DWG

THIS PLAN IS PHASE 3 OF A 3 PHASE STRATA PLAN UNDER SECTION 224 OF THE STRATA PROPERTY ACT LYING WITHIN THE JURISDICTION OF THE APPROVING OFFICER FOR CITY OF SURREY

THIS PLAN LIES WITHIN THE METRO VANCOUVER REGIONAL DISTRICT - CITY OF SURREY

THE BUILDINGS INCLUDED IN THIS STRATA PLAN HAVE NOT BEEN PREVIOUSLY OCCUPIED.

THE BUILDINGS SHOWN ON THIS STRATA PLAN ARE WITHIN THE EXTERNAL BOUNDARIES OF THE LAND THAT IS THE SUBJECT OF THE STRATA PLAN.

THE FIELD SURVEY REPRESENTED BY THIS PLAN WAS COMPLETED ON THE 25th DAY OF APRIL, 2019
GU GORDON YU, BCLS #808

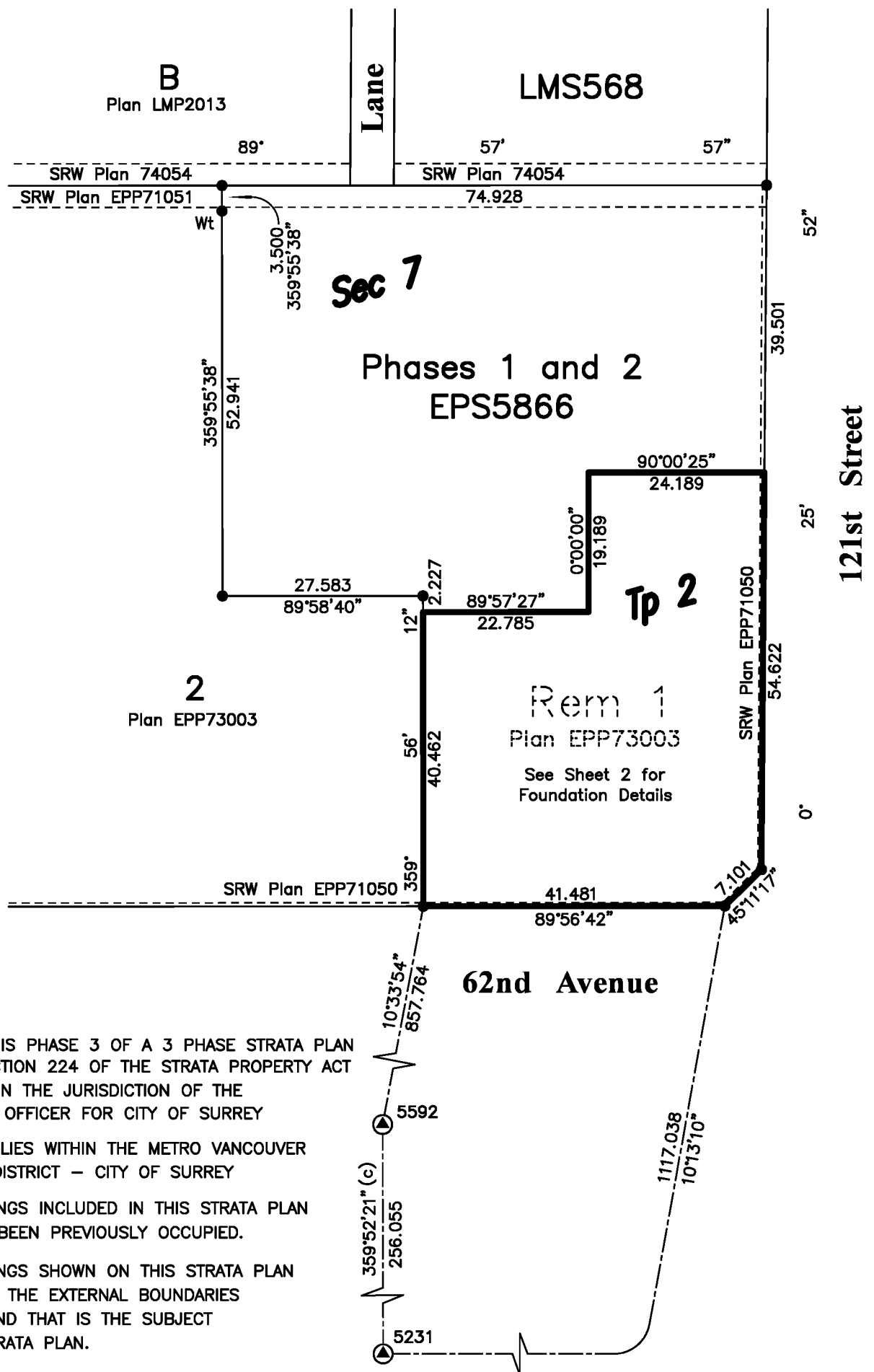

FOUNDATION DETAILS

PHASE 3 STRATA PLAN EPS5866

SHEET 2 OF 8 SHEETS

SCALE 1:250



All distances are in metres.

THE INTENDED PLOT SIZE OF THIS PLAN IS 280 mm IN WIDTH BY 432 mm IN HEIGHT (B SIZE) WHEN PLOTTED AT A SCALE OF 1:250

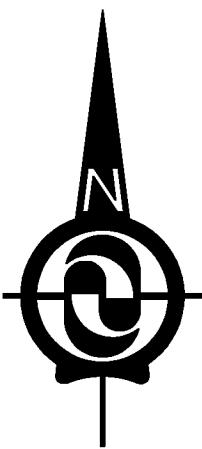

Phases 1 and 2 EPS5866

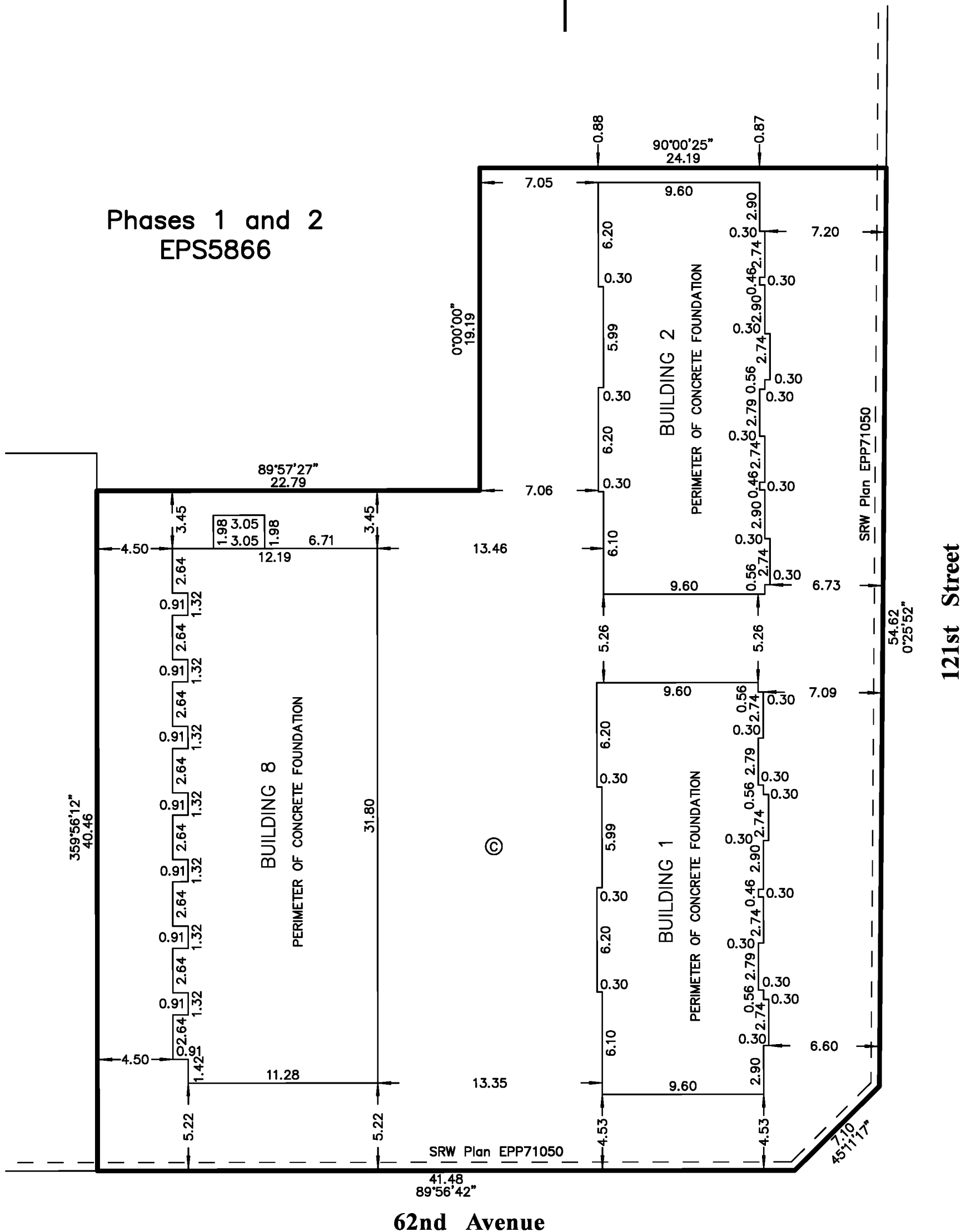

**H.Y. AND ASSOCIATES
LAND SURVEYING LTD.**

200, 9128 - 152nd STREET
SURREY, B.C.
V3R 4E7
(ph) 583-1616

File: 154271_PH3_PG2.DWG

GU GORDON YU, BCLS #808
DATE: APRIL 25, 2019

BUILDING 1

SCALE 1:200



All distances are in metres.

THE INTENDED PLOT SIZE OF THIS PLAN IS 280 mm IN WIDTH BY 432 mm IN HEIGHT (B SIZE) WHEN PLOTTED AT A SCALE OF 1:200

----- PERIMETER OF FLOOR BELOW

PHASE 3 STRATA PLAN EPS5866

SHEET 3 OF 8 SHEETS

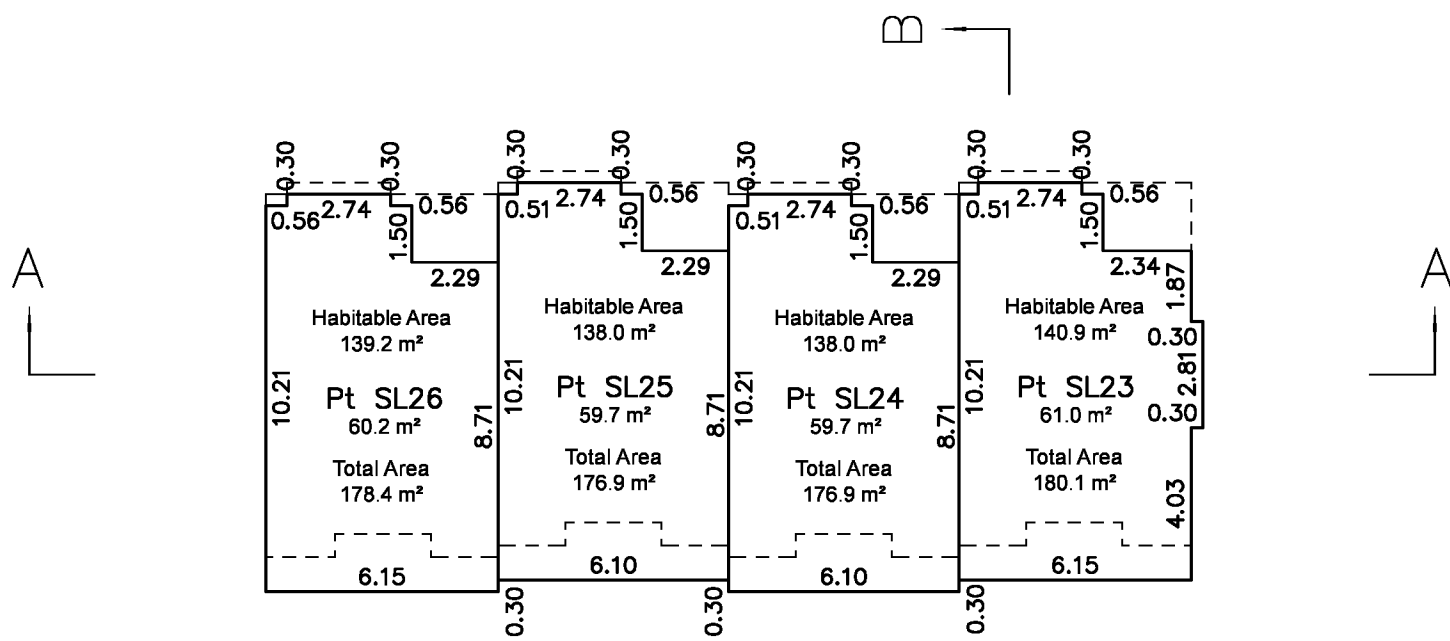
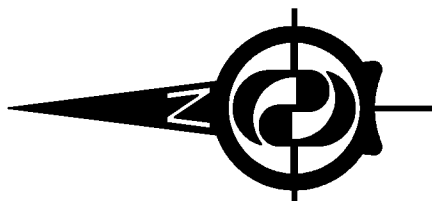

Level 3

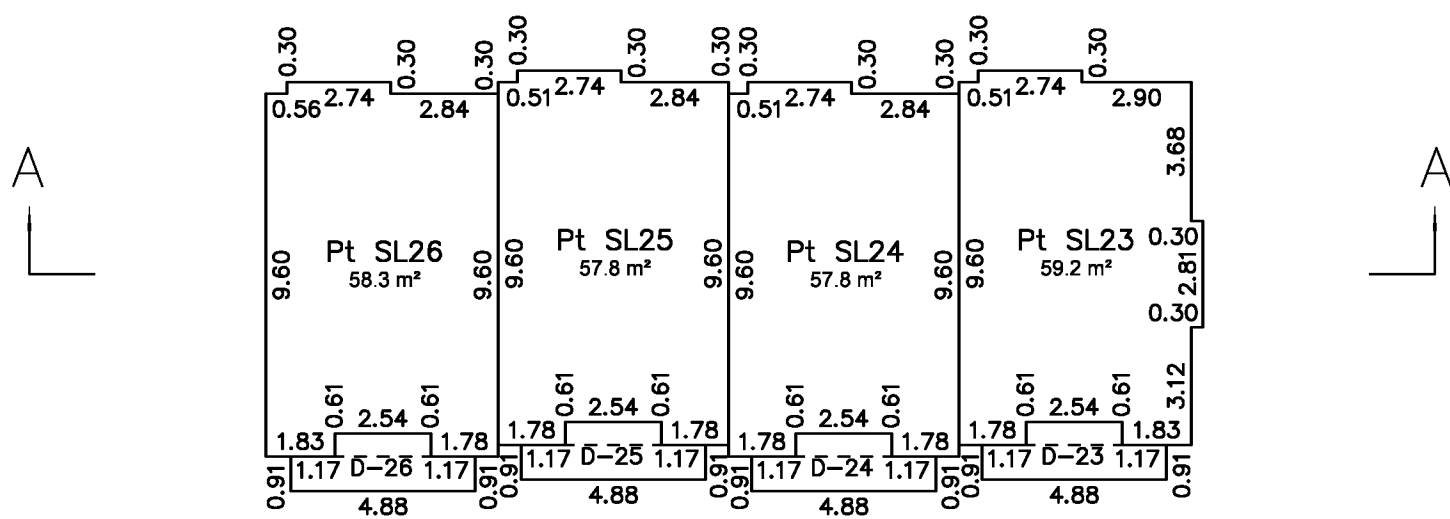

Level 2

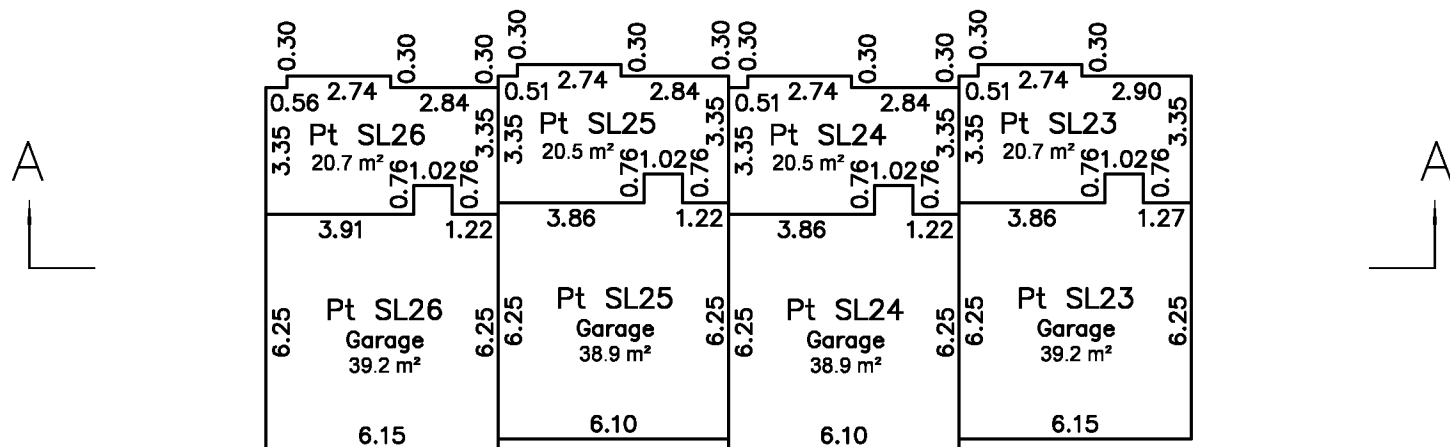

Level 1

**H.Y. AND ASSOCIATES
LAND SURVEYING LTD.**

200, 9128 - 152nd STREET
SURREY, B.C.
V3R 4E7
(ph) 583-1616
File: 154271_1.DWG

GU GORDON YU, BCLS #808
DATE: APRIL 25, 2019

BUILDING 2

SCALE 1:200



All distances are in metres.

THE INTENDED PLOT SIZE OF THIS PLAN IS 280 mm IN WIDTH BY 432 mm IN HEIGHT (B SIZE) WHEN PLOTTED AT A SCALE OF 1:200

----- PERIMETER OF FLOOR BELOW

PHASE 3 STRATA PLAN EPS5866

SHEET 4 OF 8 SHEETS

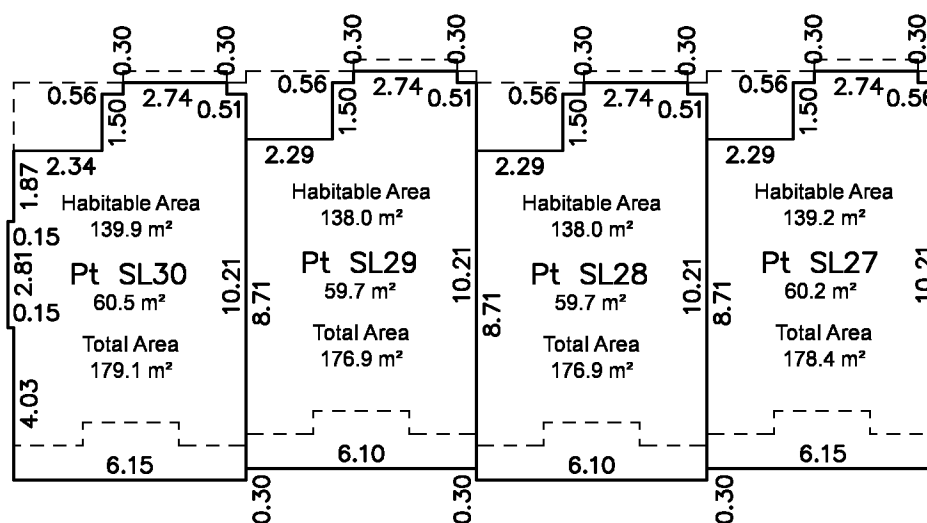
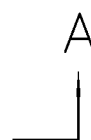
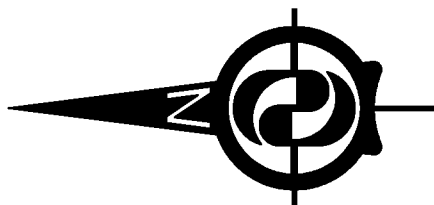

Level 3

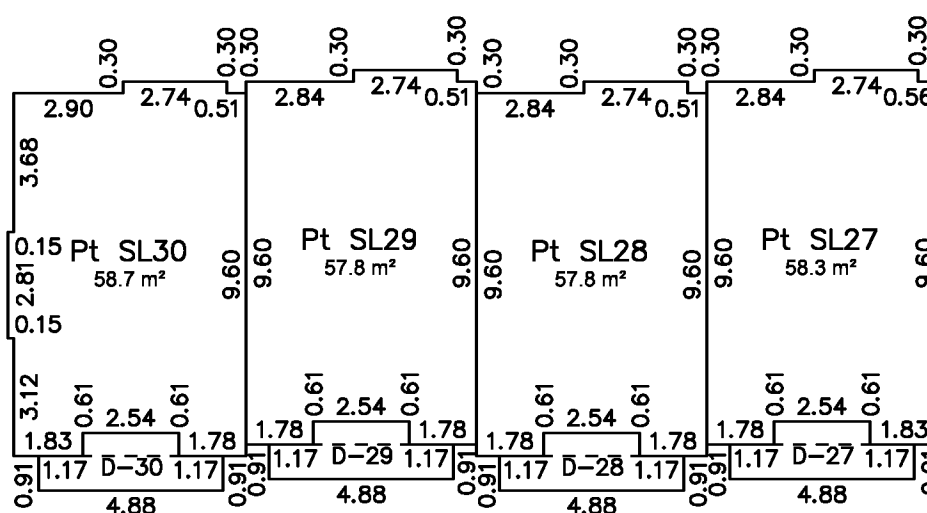
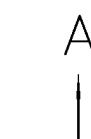

Level 2

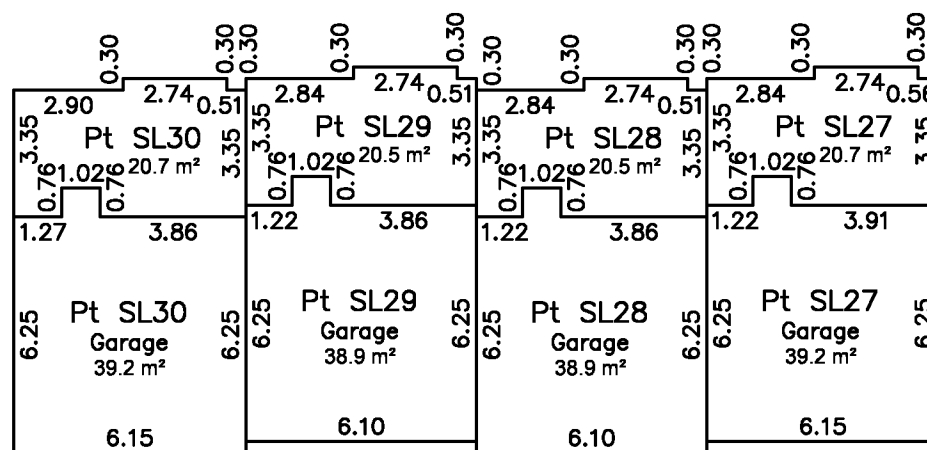
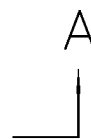

Level 1

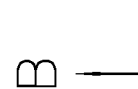

**H.Y. AND ASSOCIATES
LAND SURVEYING LTD.**

200, 9128 - 152nd STREET
SURREY, B.C.
V3R 4E7
(ph) 583-1616
File: 154271_2.DWG

GU GORDON YU, BCLS #808
DATE: APRIL 25, 2019

BUILDING 8

PHASE 3 STRATA PLAN EPS5866

SHEET 5 OF 8 SHEETS

SCALE 1:200



All distances are in metres.

THE INTENDED PLOT SIZE OF THIS PLAN IS 280 mm IN WIDTH BY 432 mm IN HEIGHT (B SIZE) WHEN PLOTTED AT A SCALE OF 1:200

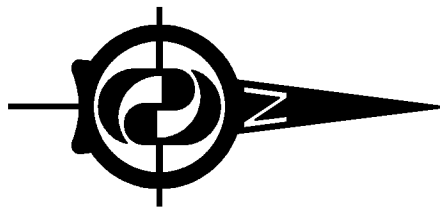

----- PERIMETER OF FLOOR BELOW

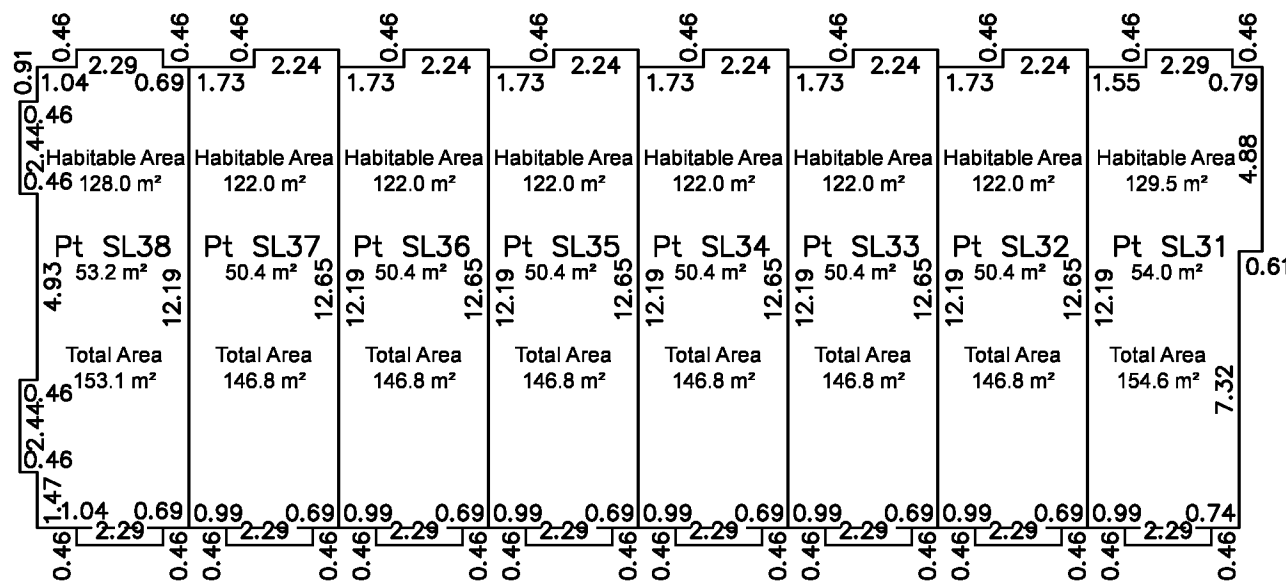

Level 3

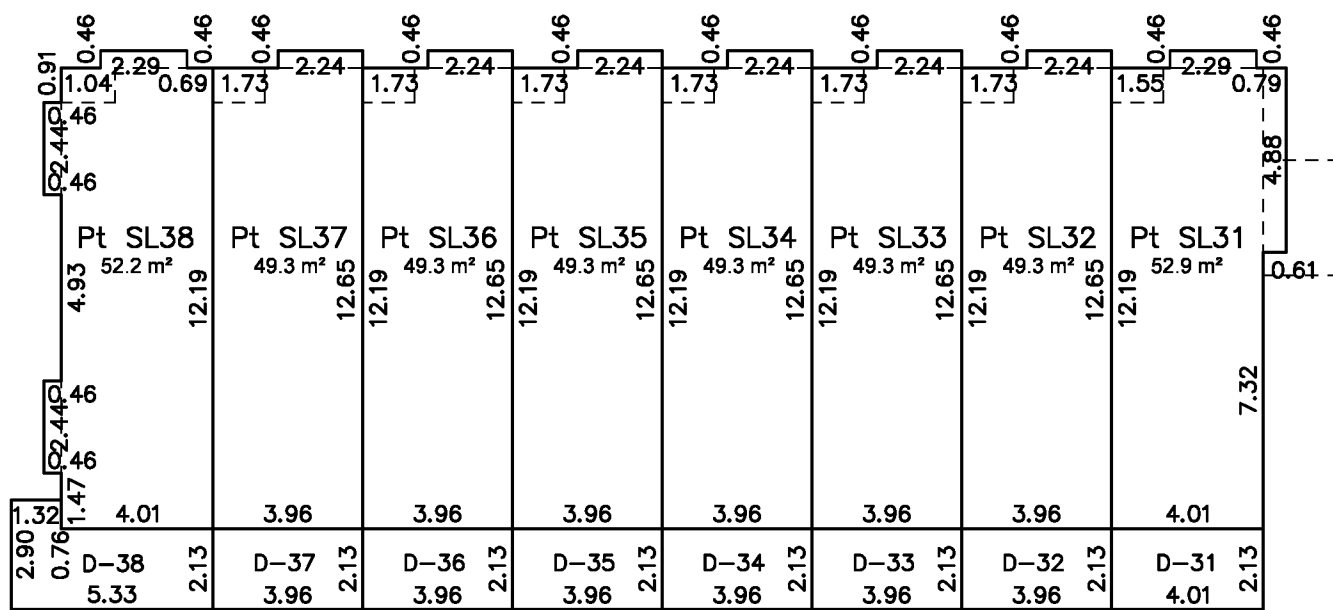

Level 2

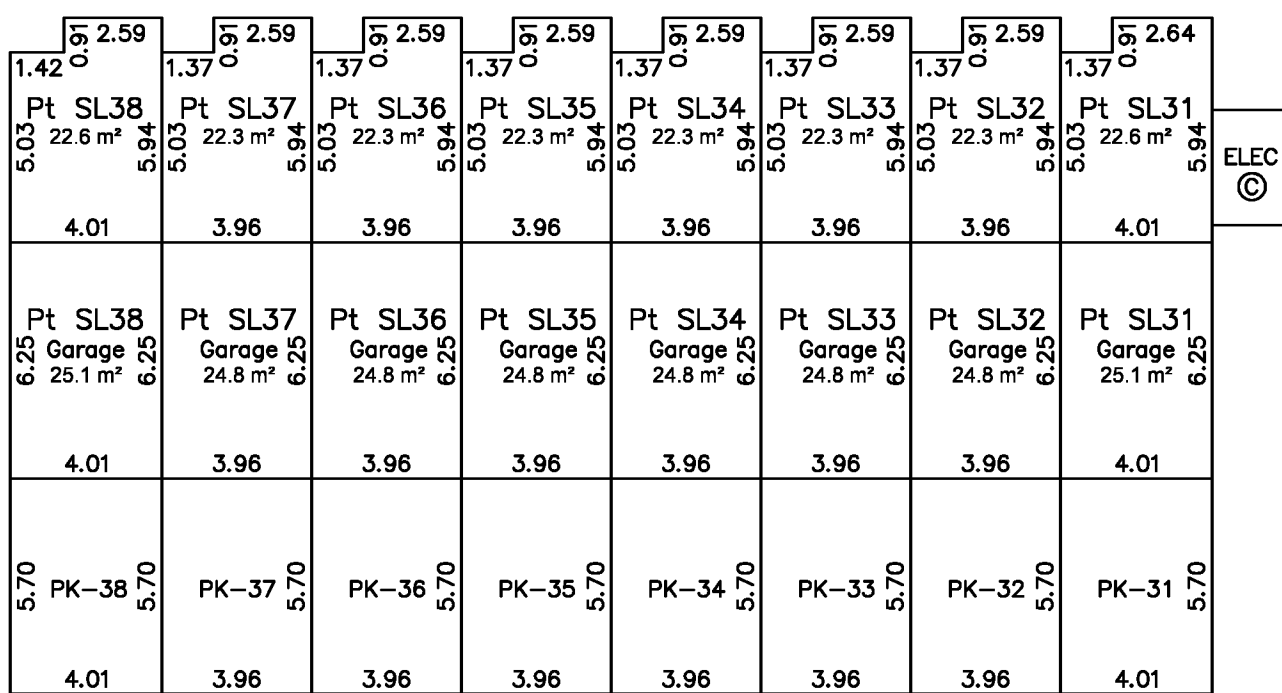
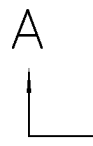

Level 1

H.Y. AND ASSOCIATES
LAND SURVEYING LTD.

200, 9128 - 152nd STREET
SURREY, B.C.
V3R 4E7
(ph) 583-1616

File: 154271_8.DWG

GU GORDON YU, BCLS #808
DATE: APRIL 25, 2019

CROSS SECTIONS OF BUILDING 1

PHASE 3 STRATA PLAN EPS5866

SHEET 6 OF 8 SHEETS

SCALE 1:200



All distances are in metres.

THE INTENDED PLOT SIZE OF THIS PLAN IS 280 mm IN WIDTH BY 432 mm IN HEIGHT (B SIZE) WHEN PLOTTED AT A SCALE OF 1:200

STRATA LOT BOUNDARIES DEFINED:

- UNDERSIDE OF CONCRETE SLAB OF GROUND FLOOR
- MIDPOINT OF STRUCTURAL PORTION OF CEILING
- MIDPOINT OF STRUCTURAL PORTION OF PARTY WALLS
- OUTSIDE OF STRUCTURAL PORTION OF EXTERIOR WALLS

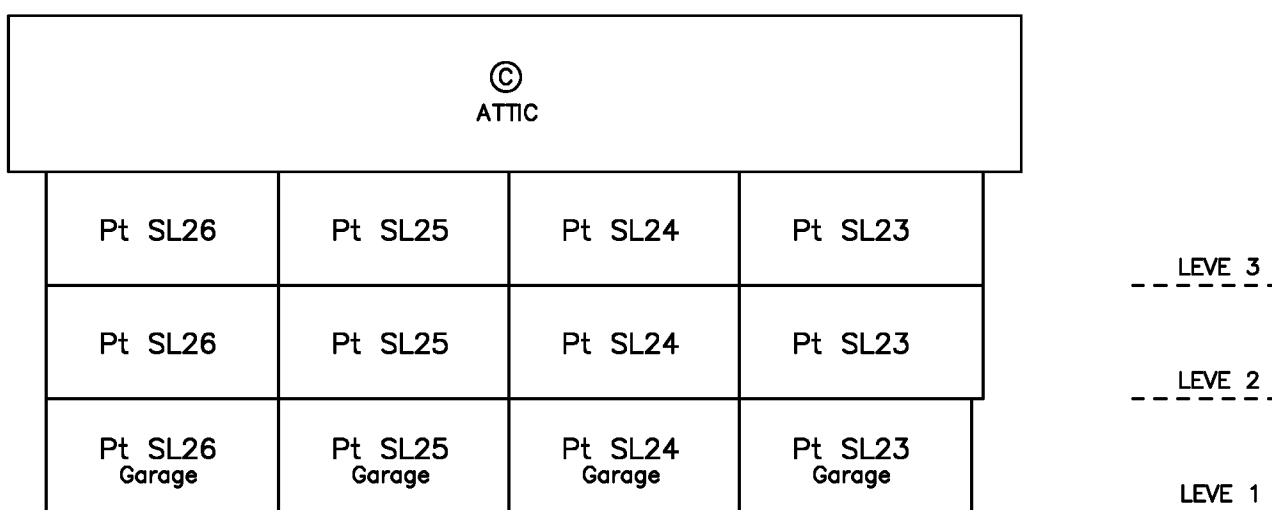

CROSS SECTION A-A

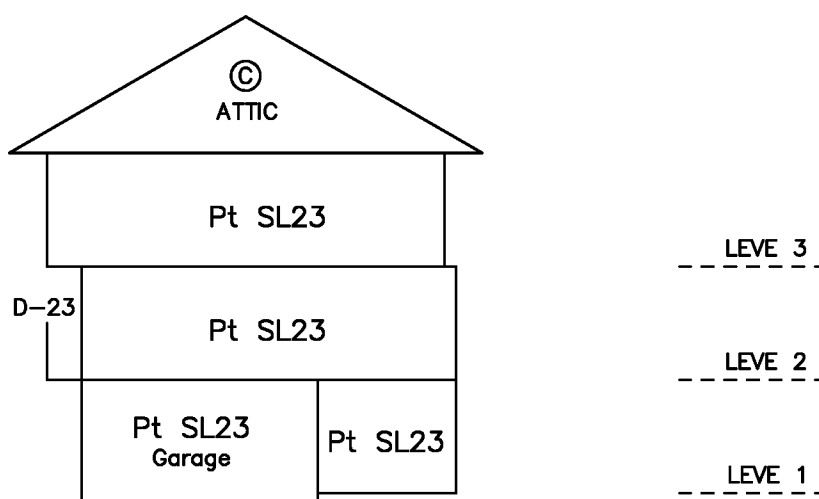

CROSS SECTION B-B

H.Y. AND ASSOCIATES LAND SURVEYING LTD.

200, 9128 - 152nd STREET
 SURREY, B.C.
 V3R 4E7
 (ph) 583-1616
 File: 154271_1_SEC.DWG

GU GORDON YU, BCLS #808
 DATE: APRIL 25, 2019

CROSS SECTIONS OF BUILDING 2

PHASE 3 STRATA PLAN EPS5866

SHEET 7 OF 8 SHEETS

SCALE 1:200

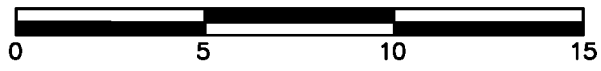

All distances are in metres.

THE INTENDED PLOT SIZE OF THIS PLAN IS 280 mm IN WIDTH BY 432 mm IN HEIGHT (B SIZE) WHEN PLOTTED AT A SCALE OF 1:200

STRATA LOT BOUNDARIES DEFINED:

- UNDERSIDE OF CONCRETE SLAB OF GROUND FLOOR
- MIDPOINT OF STRUCTURAL PORTION OF CEILING
- MIDPOINT OF STRUCTURAL PORTION OF PARTY WALLS
- OUTSIDE OF STRUCTURAL PORTION OF EXTERIOR WALLS

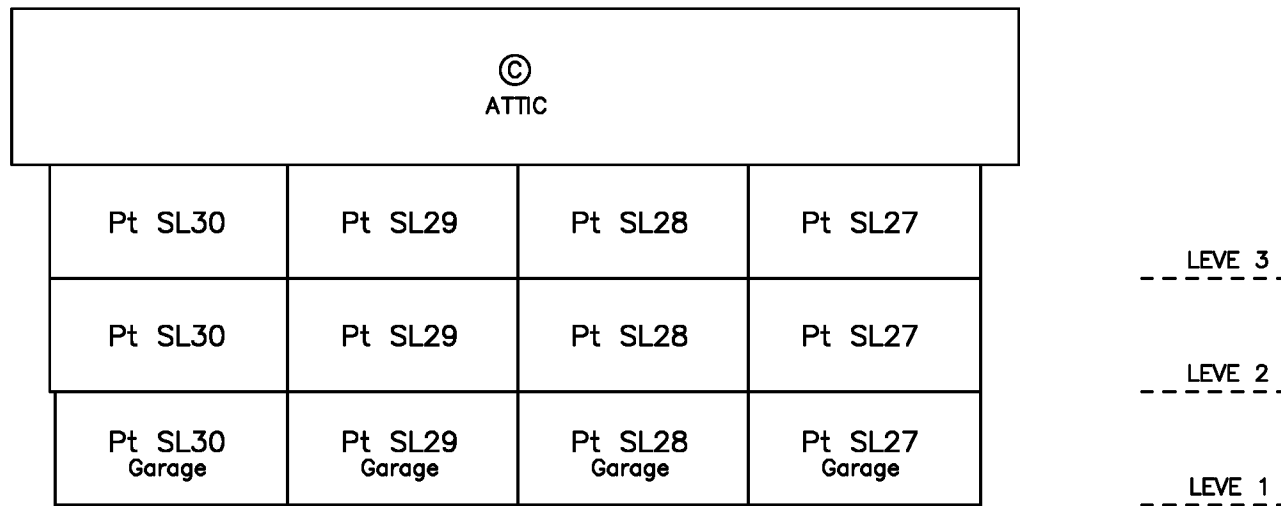

CROSS SECTION A-A

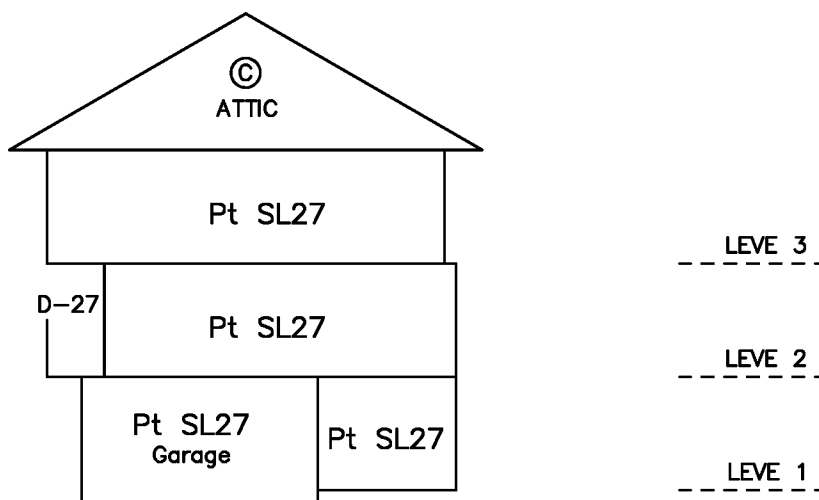

CROSS SECTION B-B

H.Y. AND ASSOCIATES LAND SURVEYING LTD.

200, 9128 - 152nd STREET
 SURREY, B.C.
 V3R 4E7
 (ph) 583-1616
 File: 154271_2_SEC.DWG

GU GORDON YU, BCLS #808
 DATE: APRIL 25, 2019

CROSS SECTIONS OF BUILDING 8

PHASE 3 STRATA PLAN EPS5866

SHEET 8 OF 8 SHEETS

SCALE 1:200



All distances are in metres.

THE INTENDED PLOT SIZE OF THIS PLAN IS 280 mm IN WIDTH BY 432 mm IN HEIGHT (B SIZE) WHEN PLOTTED AT A SCALE OF 1:200

STRATA LOT BOUNDARIES DEFINED:

- UNDERSIDE OF CONCRETE SLAB OF GROUND FLOOR
- MIDPOINT OF STRUCTURAL PORTION OF CEILING
- MIDPOINT OF STRUCTURAL PORTION OF PARTY WALLS
- OUTSIDE OF STRUCTURAL PORTION OF EXTERIOR WALLS

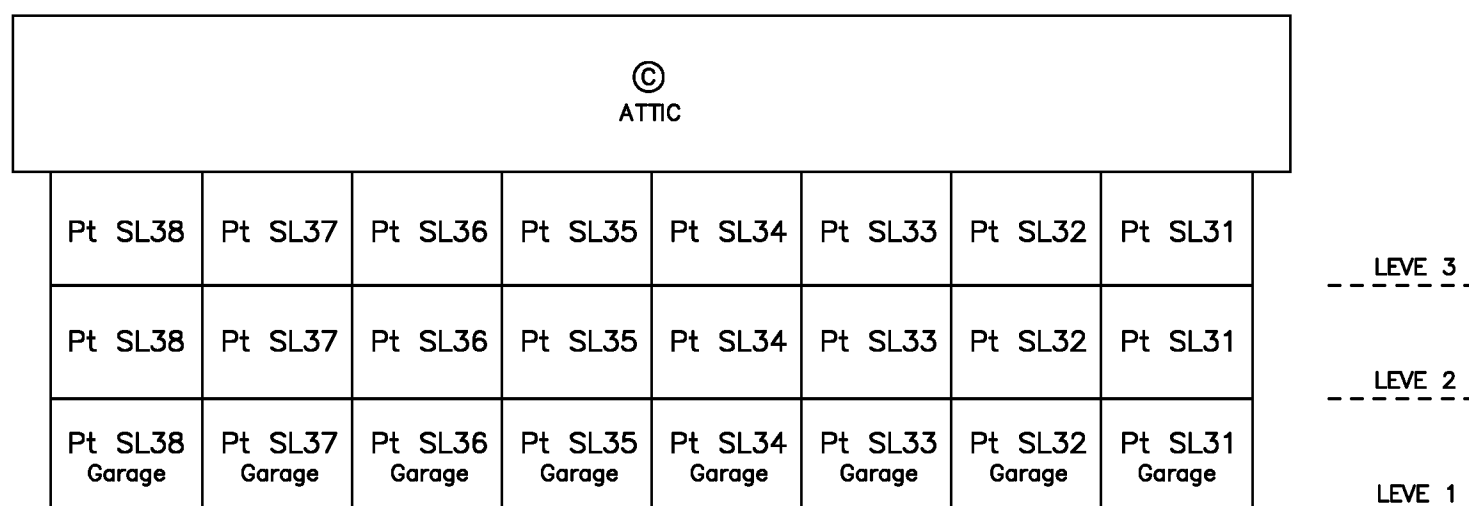

CROSS SECTION A-A

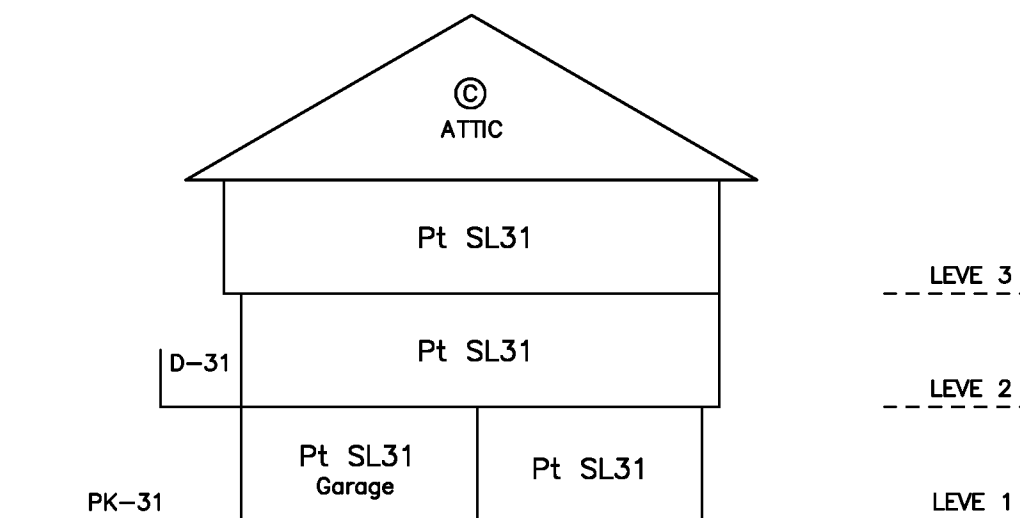

CROSS SECTION B-B

**H.Y. AND ASSOCIATES
LAND SURVEYING LTD.**

200, 9128 - 152nd STREET
SURREY, B.C.
V3R 4E7
(ph) 583-1616
File: 154271_8_SEC.DWG

GU GORDON YU, BCLS #808
DATE: APRIL 25, 2019